

24. WARRANTY LIMITATIONS, CLAIMS AND SERVICE:

Contact your professional installer for all service. Service by anyone other than a professional installer voids this warranty. If you cannot locate your installer, please contact a Marantec Customer Service Representative at 1-888-622-2489.

Marantec accessories include such items as transmitters, wall controls, photo eye systems, and wireless/keyless entry systems. These are warranted to be free from defects and workmanship for 1 year from the date of purchase. At Marantec's sole option, Marantec may elect to replace the accessory with new or reconditioned parts, components or units utilizing product of the same or similar design available at that given time. **WITH RESPECT TO ACCESSORIES, ALL OTHER WARRANTIES, INCLUDING FITNESS FOR PARTICULAR PURPOSE AND MERCHANTABILITY ARE SPECIFICALLY DISCLAIMED AND THE LIMITED WARRANTY SET FORTH BELOW IN BOLD TYPE IS HEREIN INCORPORATED BY REFERENCE. ALL OF THE DISCLAIMERS AND LIMITATIONS WITH RESPECT TO THE DOOR OPENER SYSTEM ABOVE ARE HEREIN INCORPORATED BY REFERENCE.**

MARANTEC AMERICA CORPORATION'S LIABILITY IS EXPRESSLY LIMITED TO THE RETAIL COST OF THE PARTICULAR ACCESSORY UNDER WARRANTY

Marantec does not warrant batteries, light bulbs, LED lighting and sensors, unauthorized repairs or repair parts, installations, commercial use, damage while in transit, defects or damage resulting from power washing, water or moisture exposure, or accidents, resulting from alterations, lack of proper maintenance, unauthorized repair or modification of the product, misuse or abuse of the product, fire, flood, acts of God, or other failures due to failure to follow the recommendations of the Owner's Manual. This warranty applies only to Marantec systems purchased and used in the United States, Canada or Mexico.

This limited warranty is the one which Marantec gives on this product and sets forth all of its responsibilities regarding the Marantec product. There are no other express or implied warranties. Installation by unauthorized personnel or use of unauthorized parts or accessories could cause improper operation and even created dangerous conditions and void all warranties. This would violate the UL Safety Approval of the product and constitute a safety hazard.

This Limited Warranty contains the entire warranty on the product. All discussions, representations or negotiations between the consumer and the retail seller are merged into this Limited Warranty, and there are no understandings or warranties other than those herein. None of the terms of the Limited Warranty shall be waived or modified to any extent, except by a written instrument signed and delivered by Marantec's Corporate Officer.

This Limited Warranty is being delivered at the place of manufacture, Gurnee, Illinois, is intended to be performed in the State of Illinois and shall be construed and enforced in accord with the laws and statutes of the State of Illinois with the proper venue for any disputes being that of Marantec's registered office in Chicago, Illinois or its corporate offices in Gurnee, Illinois, whichever Marantec elects. In the event any action or proceeding or claim is asserted or brought against Marantec, if Marantec prevails, then Marantec shall be entitled to recover all costs and expenses, including the actual fees of its attorneys and expert or professional witnesses incurred in connection with such action or proceeding or claim.

Whenever possible, each provision of this Limited Warranty shall be interpreted in such a manner as to be effective and valid under applicable Illinois law. If any provisions of this Limited Warranty are prohibited or invalidated under applicable law, then such provisions shall only be ineffective to the extent of such prohibition or invalidity, without invalidating the remaining provisions of this Limited Warranty.

Some jurisdictions do not allow the exclusion or limitation of consequential, incidental or special damages, so the above limitations or exclusions may not apply to you. This Limited Warranty gives you specific legal rights and you may also have other rights which vary from state to state.

25. REGISTRATION:

After installation by your professional installer, this Warranty becomes effective upon registration at the Marantec web site: www.marantecamerica.com. If you do not have access to the internet, please complete and mail in the registration card enclosed with instruction manual.

M Line[®] M4900e

Driven by
[E] [O] [S] EASY
OPERATING
SYSTEM]

Digital Intelligence for the Garage

Owner's Manual contains:
Installation, operating, maintenance &
warranty instructions.
For residential use only.



Marantec America Corporation
5705 Centerpoint Court, Gurnee, IL 60031 U.S.A.
Phone 1-888-622-2489 • Fax 847-478-0348

Marantec

Access Systems ▶ Automatically The Best Choice

www.marantecamerica.com



OWNER'S MANUAL CONTENTS

1.	INTRODUCTION	3
2.	ADVANCED FEATURES	3
3.	IMPORTANT SAFETY INFORMATION	3
4.	TOOLS	4
5.	GARAGE	4
6.	OPERATOR PACKAGE CONTENTS	5
7.	IMPORTANT INSTALLATION INSTRUCTIONS	6
8.	INSTALLATION STEPS	7
8-1.	ATTACH RAIL TO OPERATOR HEAD	7
8-2.	MEASURE AND MARK DOOR AREA	7
8-3.	INSTALL DOOR BRACKET TO DOOR	8
8-4.	INSTALL HEADER BRACKET	8
8-5.	ATTACH RAIL TO HEADER BRACKET	9
8-6.	POSITION OPERATOR FOR MOUNTING	9
8-7.	MOUNT OPERATOR TO CEILING	9
8-8.	CONNECT ARM TO DOOR AND TROLLEY	10
8-9.	CHECK EMERGENCY RELEASE	11
8-10.	INSTALL LIGHT BULBS AND LENSES	11
8-11.	INSTALL THE PHOTO EYE SENSOR SAFETY SYSTEM	12
8-12.	INSTALL WALL CONTROL PANEL	13
8-13.	CONNECTING WIRES TO OPERATOR	13
8-14.	CONNECT TO POWER	14
8-15.	CONTROL PANEL	15
8-16.	INITIAL SYSTEM SET UP	15
8-17.	ADVANCED SETTING	17
8-18.	TEST SAFETY REVERSAL	21
8-19.	ALIGN AND TEST PHOTO EYE SENSORS	21
8-20.	APPLY LABELS TO INSIDE OF GARAGE	22
8-21.	ATTACH OWNER'S MANUAL TO WALL	22
9.	IMPORTANT SAFETY INSTRUCTIONS	22
10.	TRANSMITTERS	26
11.	WIRELESS KEYLESS ENTRY SYSTEM	24
12.	OPERATION OF YOUR OPERATOR	25
13.	MODULAR ANTENNA	26
14.	LOCMATIC READY	26
15.	HOMELINK® TRANSCEIVER	26
16.	BELT DRIVE ASSEMBLY	26
17.	TENSION ADJUSTMENT	26
18.	OPERATOR ASSEMBLY PARTS	27
19.	ACCESSORIES	28
20.	HAVING A PROBLEM?	29
21.	TROUBLESHOOTING - FOR PROFESSIONAL INSTALLERS ONLY	30
22.	MAINTENANCE AND ADJUSTMENTS	31
23.	LIMITED PARTS WARRANTY	31
24.	WARRANTY LIMITATIONS, CLAIMS AND SERVICE	32
25.	REGISTRATION	32

22. MAINTENANCE AND ADJUSTMENTS

To ensure continued safe operation and extended life of your operator system, periodic checking for proper operation is necessary. Occasional maintenance and readjustment of your system may also be needed.

MONTHLY:

- Check reversal system by performing "safety reversal test" described in this manual.
- Check proper operation of door by manually moving door open and closed. If door binds or sticks, or is out of balance call for garage door service.
- Check and test photo eye safety system as described in this manual.

ONCE EVERY YEAR

- Keep door rollers, hinges, and bearings properly lubricated by following recommended door instructions or contacting a door service company in your area.

AS NEEDED:

- Readjust operator travel limits and force settings as necessary — due to cold weather, normal wear of door, etc. The convenient adjustment instruction label on the operator can be used for any periodic adjustments needed.
- Check and readjust belt tension, if necessary, in the unlikely event that it loses its proper tension during the life of the operator. Always check the reversal system after any adjustment of travel limits or forces. A door operator that is not checked could possibly be out of adjustment and be dangerous.

23. LIMITED PARTS WARRANTY

MARANTEC AMERICA CORPORATION PROFESSIONAL SERIES GARAGE DOOR OPERATOR SYSTEM M4900e Product Warranty — Parts Limited Lifetime on Operator & Rail *Labor Not Included in Warranties*

THIS LIMITED WARRANTY IS FOR THE ORIGINAL PURCHASER OF THE MARANTEC RESIDENTIAL GARAGE DOOR OPERATOR

Coverage: THIS LIMITED WARRANTY IS FOR THE ORIGINAL PURCHASER OF THE MARANTEC RESIDENTIAL GARAGE DOOR OPERATOR. This Warranty applies, upon purchase from an authorized Marantec reseller and installation by a professional installer and registration of the product within 14 days (or within 30 days of closing on a new home purchase from a developer) of the date of installation of the product, to any defect in materials or workmanship in the Marantec product parts or components from personal, normal household use in compliance with the Owner's Manual. Marantec warrants this garage door opener system to its first retail, consumer purchaser. This is not a commercial product. Marantec disclaims any and all warranties in the event that the product is obtained from a source which is not a Marantec authorized reseller or if the product is not installed by a professional installer. "Grey market" and counterfeit purchases are not warranted or recognized in any manner whatsoever. This is not a "do it yourself" product. No "aftermarket" installation, alteration, modification or repairs are recognized or warranted. Any of the foregoing conduct voids all warranty provisions. This warranty is for parts only and is not for any service call(s) or labor in connection with the repair or replacement of the unit or its parts. Parts will only be shipped to your Marantec authorized reseller.

Marantec Commitment: If Marantec determines the product parts to be defective in materials or workmanship, then Marantec will supply parts for the repair or replacement of the defect to the Marantec authorized professional installer at no cost to you. You must pay for the service call and labor for installation of the part(s) determined to be defective by Marantec. At Marantec's sole option, Marantec may elect to replace the part(s) with new or reconditioned parts, components or units utilizing product of the same or similar design available at that given time.

THIS LIMITED WARRANTY IS IN LIEU OF ANY OTHER WARRANTIES, EXPRESS OR IMPLIED, INCLUDING ANY IMPLIED WARRANTIES OF MERCHANTABILITY OR FITNESS FOR A PARTICULAR PURPOSE, OR OTHER WARRANTIES IMPLIED BY STATUTE, AND OF ANY OTHER OBLIGATIONS OR LIABILITY ON THE PART OF MARANTEC AMERICA CORPORATION. THIS LIMITED WARRANTY DOES NOT COVER NON-DEFECT DAMAGE CAUSED BY IMPROPER INSTALLATION, OPERATION OR CARE AND MAINTENANCE, INCLUDING BUT NOT LIMITED TO ABUSE, MISUSE, POWER SURGE, FAILURE TO PROVIDE REASONABLE AND NECESSARY MAINTENANCE OR ANY ALTERATIONS TO THIS PRODUCT, INCLUDING ACCESSORIES. LABOR CHARGES FOR DISMANTLING OR REINSTALLING A REPAIRED OR REPLACED UNIT ARE EXCLUDED.



MARANTEC AMERICA CORPORATION'S LIABILITY IS EXPRESSLY LIMITED TO THE RETAIL COST OF THE PARTICULAR UNIT UNDER WARRANTY.

UNDER NO CIRCUMSTANCES SHALL MARANTEC AMERICA CORPORATION BE LIABLE FOR CONSEQUENTIAL, INCIDENTAL OR SPECIAL DAMAGES ARISING IN CONNECTION WITH THE USE OR INABILITY TO USE THIS PRODUCT OR THE PREMISES IN WHICH IT IS UTILIZED. IN NO EVENT SHALL MARANTEC AMERICA CORPORATION INCUR LIABILITY FOR BREACH OF WARRANTY, BREACH OF CONTRACT, NEGLIGENCE OR STRICT LIABILITY IN EXCESS OF THE COST OF THE PRODUCT, INCLUDING ACCESSORIES, COVERED HEREBY. NO PERSON IS AUTHORIZED TO ASSUME, FOR MARANTEC AMERICA CORPORATION, ANY OTHER LIABILITY OR MAKE ANY MODIFICATIONS OR EXTENSIONS TO THE WARRANTY OF THIS PRODUCT. THIS LIMITED WARRANTY MAY NOT BE TRANSFERRED OR ASSIGNED.

21. TROUBLESHOOTING — FOR PROFESSIONAL INSTALLER ONLY

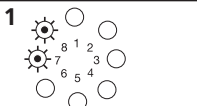
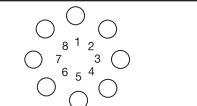
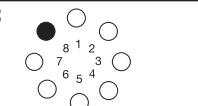
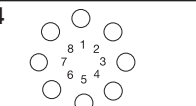
The operator displays the system fault(s) automatically one at a time as follows:

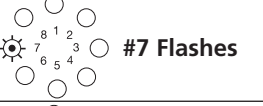
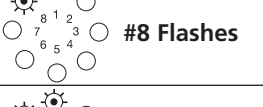
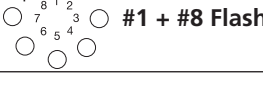
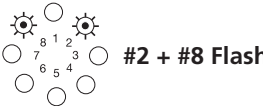
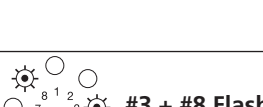
System Fault Sequence Display: (Example - Error Code 15)			
Step 1 	Step 2 	Step 3 	Step 4 
The fault code is displayed for approximately 3 seconds.	Pause between messages for approximately 1 second.	Operating mode is displayed for approximately 3 seconds (example: Operating voltage).	Pause between messages for approximately 1 second.
Step 5 : Steps 1 to 4 are repeated until all system fault(s) are cleared.			

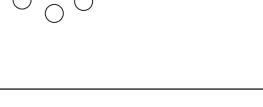
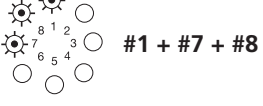
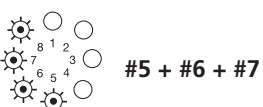
FAULT DISPLAY	CODE	PROBLEM	SOLUTION
 #7 Flashes	7	NOTICE: <ul style="list-style-type: none"> If no buttons are pressed within 120 seconds, the programming mode terminates automatically. OPEN and CLOSED door positions programmed without passing the reference point. 	
 #8 Flashes	8	<ul style="list-style-type: none"> Adjustments setting interrupted before completion. Detective reference switch. 	<ul style="list-style-type: none"> Door can be operated normally. Recheck adjustments if adjustment settings were not completed. Refer to page 16. Have operator serviced.
 #1 + #8 Flash	9	<ul style="list-style-type: none"> Defective RPM sensor/operator system blocked. 	<ul style="list-style-type: none"> Have operator serviced.
 #2 + #8 Flash	10	<ul style="list-style-type: none"> Door movement too stiff. Force required to move door exceeded set force level. Operator working force setting is too low. 	<ul style="list-style-type: none"> Check door for obstructions, proper manual operation, proper balance, or broken springs. Clear obstructions or have door serviced. If door is OK, increase force setting. Readjust force and run the operator for two (2) uninterrupted complete cycles. Refer to "Advanced settings" on page 19 – Level 2 (Menu 1 and Menu 2). REPEAT THE "SAFETY REVERSAL TEST" (page 21) AFTER ADJUSTMENT IS COMPLETE.
 #3 + #8 Flash	11	<ul style="list-style-type: none"> Operator exceeded maximum run time limit. 	<ul style="list-style-type: none"> Make sure rail is connected to operator head and belt or chain is moving.
 #7 + #8 Flash	15	<ul style="list-style-type: none"> Photo eye sensors not connected properly. Photo eye sensors not aligned. Obstruction in the door path (photo eye beam broken). 	<ul style="list-style-type: none"> Check photo eye sensors wiring and connections. Refer to pages 12 and 13. Realign photo eye sensors. Refer to page 21. Remove obstruction from door path.
 #1 + #7 + #8 Flash	16	<ul style="list-style-type: none"> Force watchdog circuit found error. The sensor which monitors the operator sensitivity has failed. 	<ul style="list-style-type: none"> Readjust the operator force(s) and run the operator for two (2) uninterrupted complete cycles. Refer to "Advanced settings" on page 19 – Level 2 (Menu 1 and Menu 2). REPEAT THE "SAFETY REVERSAL TEST" (page 21) AFTER ADJUSTMENTS ARE COMPLETE. Have the operator checked.
 #5 + #6 + #7 + #8 Flash	26	<ul style="list-style-type: none"> Undervoltage, operator system overloaded at maximum force setting (16). Operator system overloaded. 	<ul style="list-style-type: none"> Have the outlet assigned for the operator and/or supplied power checked.
 #2 + #5 + #6 + #7 + #8 Flash	28	<ul style="list-style-type: none"> Door movement too stiff or irregular. Door blocked. Operator operating sensitivity set too sensitive (low). 	<ul style="list-style-type: none"> Check door for obstructions, proper manual operation, proper balance, or broken springs. Clear obstructions or have door serviced, if needed. Have the operating sensitivity settings checked by an authorized dealer/installer (Refer to "Advanced settings" on page 19 - Level 2 (Menu 3 and Menu 4). Run the operator for two (2) uninterrupted complete cycles after adjustment are completed.

1. INTRODUCTION

Congratulations on purchasing your Marantec® Professional Series Garage Door Operator System (GDO), the most innovative operator available today. This stylishly designed digital operator with a wide range of accessories is engineered to provide the smoothest, quietest and safest operation to compliment any home. Advanced technology results in the operator being capable of easily moving almost any properly balanced residential garage door, and at the same time providing state-of-the-art safety features to detect obstructions and to stop and reverse the door, thus helping to protect persons and property near the door.

2. ADVANCED FEATURES

This operator includes numerous state-of-the-art features to provide you, the user, with years of trouble-free, convenient, and safe use of your automatic garage door operator.

- Advanced Digital Operating System EOS (Easy Operating System):** The EOS digital system provides an user friendly system set up. The system set up comprises of two programming levels, an "Initial Level" and an "Advanced Level". The EOS system requires only the initial set up parameters. All other operating parameters are learned and set automatically by the system. In addition, the system optimizes all parameters with every cycle for a more efficient operation by the GDO. This shorter parameter set up provides a quicker and more efficient installation.
- Precision Controlled DC Motor, Complete with Automatic Soft Start and Soft Stop Feature:** The operator automatically detects when your door is almost fully closed or fully opened, and gradually slows the door down before it reaches its fully closed or opened position. During start-up, the door starts moving slowly and gradually ramps up to full speed for the full travel of your door. This reduces the possible damaging effects of the sudden starts and stops associated with some other operators, and results in the smooth operation and increased service life of your door and hardware.
- Built-In Safety Features:** Including patented drive system that delivers only the optimum power needed to move your door safely - Every time!
- Modular Antenna Concept (patented):** Plug-in your choice of frequency module.
- Photo Eye (Infrared) Safety System:** State-of-the-art infrared beam system helps detect obstructions in the path of your door and automatically reverses closing door travel, helping to protect persons and property near the door.
- Convenient Status Display:** To indicate the status of your door operator at any time. Especially useful if troubleshooting is necessary.
- Quiet, Smooth Operation:** Precision engineering and carefully selected materials result in extremely smooth and quiet operation, unmatched by conventional garage door operators.
- The EOS platform unifies all Marantec Products by design.**

3. IMPORTANT SAFETY INFORMATION

This manual is essential to the safe and proper installation, operation, and maintenance of your operator. Read and follow all guidelines and operating instructions before the first use of this product. Store the manual in a safe, easily accessible location.



Operate the garage door operator at 120V, 60Hz to avoid operator damage.

Garage doors are heavy, moving objects. When coupled with an automatic operator, electrical power is also present. If not properly installed, balanced, operated, and maintained, an automatic door can become dangerous and cause serious injury or death. Please pay close attention to the WARNING and CAUTION notices that appear throughout this manual. Failure to follow certain instructions may result in damage to the door or door opener, or may result in severe injury or death to yourself or others.



WARNING means that severe injury or death could result from failure to follow instructions.



CAUTION means that property damage or injury could result from failure to follow instructions.

4. TOOLS

The instructions will refer to the tools shown below for proper installation, adjustment, and maintenance of the garage door operator. Additional tools may be required depending on your particular installation.

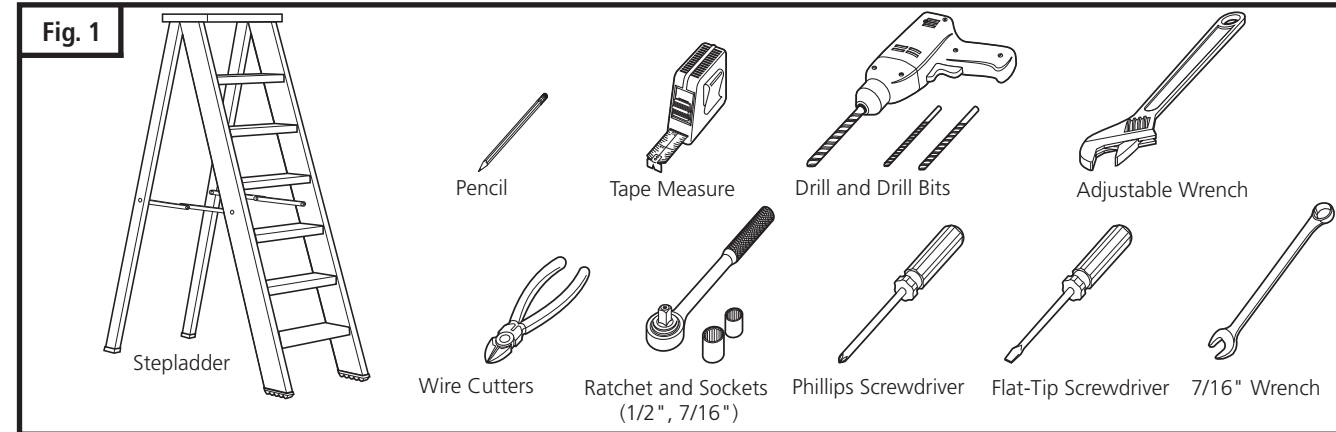

5. GARAGE

WARNING

A garage door is a heavy moving object and can cause serious injury or death. An unbalanced door might not reverse when required, and can increase the risk of injury. If your garage door is out of balance, or if it binds or sticks, call for professional garage door service. Garage doors, springs, pulleys, cables, and hardware are under extreme tension and can cause serious injury or death. Do not try to adjust them yourself. Ropes left on a garage door could cause someone to become entangled and could kill them. Remove all ropes connected to the door before installing your operator.

Take a moment to survey your garage and garage door.

- Is there an access door besides the garage door? If not, you should install an emergency key release kit.
- With the garage door closed, check alignment of door and garage floor. The gap, if any, should be no more than 1/4". If the gap is larger than this, repair floor or door before installing operator.
- The operator is intended for installation on a properly balanced and adjusted garage door. DO NOT INSTALL IF DOOR IS UNBALANCED OR BROKEN.
- Check balance of door in mid travel and during full range of opening and closing. Lift the door about half way, as shown in Fig. 2. Release the door. It should remain in place, supported by its springs. Raise and lower the door fully to check for binding or sticking.

GARAGE DOOR OPERATOR SYSTEM OVERALL DIMENSIONS (7' DOOR)

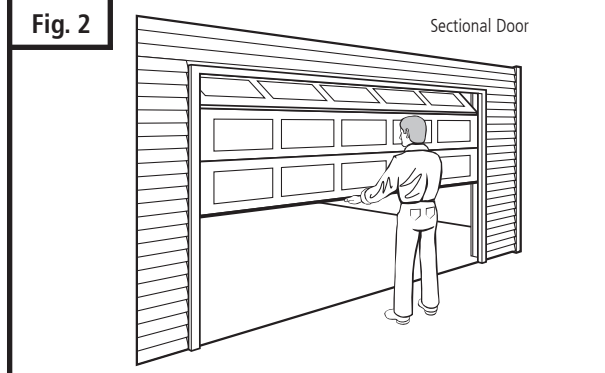
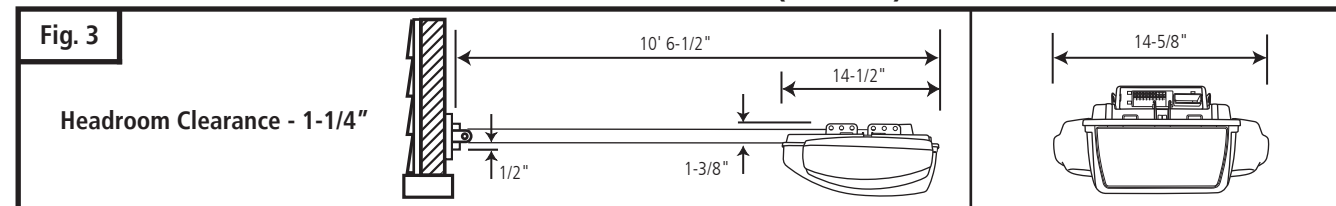

- If door is out of balance or needs repair, DO NOT ADJUST IT YOURSELF. CALL A QUALIFIED GARAGE DOOR SERVICE PROFESSIONAL to adjust your door.
- If your door is over 7 ft. high, you will need a longer rail. **See Section 16 "Rail Assembly" on p. 26 of this manual for availability of longer rails.**

CAUTION

To prevent damage to steel, aluminum, fiberglass or glass panel doors, always reinforce the inside of the door both vertically and horizontally with steel or angle iron bracing.

The best solution is to follow the instructions for your particular garage door or contact the garage door manufacturer for proper reinforcement instructions.

20. HAVING A PROBLEM?

SITUATION	LIKELY CAUSE AND SOLUTION
Operator does not operate from either wall control or transmitter:	<ul style="list-style-type: none"> ■ Does operator have electric power? Plug a lamp into the electric outlet to see if lamp turns on. If not, check fuse box or circuit breaker (some outlets are controlled by wall switch). ■ Have you disengaged all locks on door? If not, do so. ■ The garage door spring may be broken. Have it replaced by a professional garage door technician. ■ Has snow or ice built up under door? Door may be frozen to ground. Remove any restrictions.
Operator operates from transmitter but not from wall control:	<ul style="list-style-type: none"> ■ Are wiring connections correct? Check wall control wiring on page 13. ■ Is wall control door's Pushbutton lit? If not, disconnect low voltage wires to wall control and momentarily touch them together. If operator runs, replace wall control. If operator does not run, check wiring connections at operator, and check wire for shorts or breaks under staples.
Operator operates from wall control but not transmitter:	<ul style="list-style-type: none"> ■ Is the wall control button light flashing? If so, your opener is in the vacation / lock mode. Turn off vacation/lock mode. Refer to "Wall Control Panel" on page 25. ■ Does the transmitter indicator light glow when the transmitter button is pressed? If not, replace battery. Refer to "Battery Replacement" on page 23. ■ Has the operator learned the code of the transmitter? Repeat transmitter programming steps. Refer to "Transmitter Coding" on page 16. ■ Have all transmitters been set with the same code? Repeat code learning procedure for all remote devices. Refer to "Multiple Transmitters" on page 23. ■ Is the photo eye system obstructed? If so, door will only close while wall control door Pushbutton is pressed and held. Refer to "Align and Test Photo Eye Sensors" on page 21.
Operator does not work from HomeLink®	<ul style="list-style-type: none"> ■ Has the HomeLink® Transceiver learned the code of the transmitter? Repeat programming steps (refer to HomeLink® Manual)
Door does not open completely:	<ul style="list-style-type: none"> ■ Is something obstructing the door? Remove obstructions only after ensuring door area is free of persons, pets, and any other objects. ■ If door has been working properly but now doesn't open all the way, reset the open travel limit or/and increase the up force (page 19). REPEAT "TEST SAFETY REVERSAL" (page 21) AFTER ADJUSTMENT IS COMPLETE.
Door does not close completely:	<ul style="list-style-type: none"> ■ LED #1 "ON" Check photo eye sensor wires, connections to the operator terminals. Refer to pages 12 and 13. ■ LED #1 "Blinks" Check sensor alignment and sensor connections to the operator terminals 1 and 2. Refer to pages 13 and 21. ■ Is something obstructing the door or in the path of the photo eye sensors? Remove obstructions only after ensuring door area is free of persons, pets, and any other objects. ■ If door has been working properly but now doesn't close all the way, reset the close travel limit or/and increase the down force (page 19). REPEAT "TEST SAFETY REVERSAL" (page 21) AFTER ADJUSTMENT IS COMPLETE.
Door opens but will not close at all:	<ul style="list-style-type: none"> ■ LED #1 "ON" Check photo eye sensor wires, connections to the operator terminals. Refer to pages 12 and 13. ■ LED #1 "Blinks" Check sensor alignment and sensor connections to the operator terminals 1 and 2. Refer to pages 13 and 21. ■ Increase force in down direction. REPEAT "TEST SAFETY REVERSAL" (page 21) AFTER ADJUSTMENT IS COMPLETE.
Door reverses for no apparent reason:	<ul style="list-style-type: none"> ■ LED #1 "ON" Check photo eye sensor wires, connections to the operator terminals. Refer to pages 12 and 13. ■ LED #1 "Blinks" Check sensor alignment and sensor connections to the operator terminals 1 and 2. Refer to pages 13 and 21. ■ Is something obstructing the door? Pull emergency release knob and open door manually. If it is unbalanced or broken, call for professional garage door service. ■ Clear ice or snow from garage floor area where garage door closes. ■ If door reverses from fully closed position, decrease travel limits (page 16). ■ Review and increase force adjustment setting for down travel (page 19). ■ REPEAT "TEST SAFETY REVERSAL" (page 21) AFTER ADJUSTMENT IS COMPLETE.
Operator light does not turn on	<ul style="list-style-type: none"> ■ Replace the light bulb(s) with a standard incandescent maximum 60 Watts each. If the standard incandescent light bulb burns out prematurely, replace it with 60 Watts maximum a garage door operator incandescent light bulb. Refer to page 16 for replacement instruction.
Operator light does not turn off	<ul style="list-style-type: none"> ■ Is the wall control Light Feature on? Press Light Button to turn off. Refer to page 25.
Operator strains or maximum force is needed to operate door	<ul style="list-style-type: none"> ■ Door may be out of balance or springs are broken. To check balance, close the door and use emergency release knob to disconnect trolley. Open and close door manually. A properly balanced door will hold itself halfway open while being supported entirely by its springs. If it does not or the spring is broken, call for professional garage door service. DO NOT increase the force to the operator to compensate for unbalanced or damaged door.
Operator does not move door at all:	<ul style="list-style-type: none"> ■ Door may be locked with a manual door lock. Remove any manual door locks. ■ Springs are broken or door is out of balance. (See "Situation" immediately preceding this one).
Operator won't work due to power failure	<ul style="list-style-type: none"> ■ Use the emergency release knob to disconnect trolley. Door can be opened and closed manually. When power is restored, reconnect trolley and resume automatic operation of door. Refer to "Check Emergency Release" on page 11.

19. ACCESSORIES

The following accessories are designed to provide added convenience, satisfaction and value to your door operator system. Accessories are available from your dealer. If you have difficulty locating available accessories, please contact us directly at 1-888-622-2489 or visit our website at www.marantecamerica.com.

Fig. 53

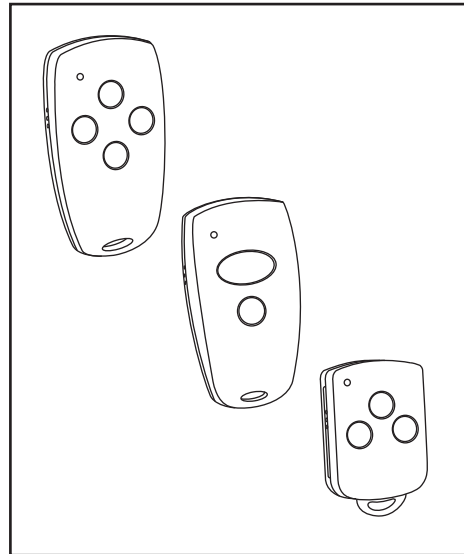

Mini & Micro Transmitters

MINI

- 2 Channel Model # M3-2312
- 4 Channel Model # M3-2314

MICRO

- 3 Channel Model # M3-3313
- Advanced multibit technology for better, more secure signal transmission.
- Battery included.
- Complete with visor clip.

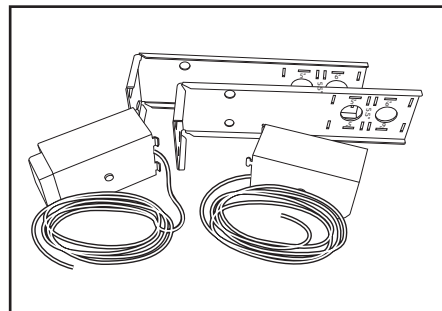
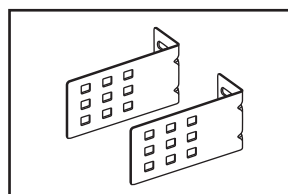

Photo Eye Safety System Model # M8-705

- Provides a system of protection for you and your family.
- Designed to suit your particular garage.



Extension Bracket Kit Part # 72802

- Hardware included

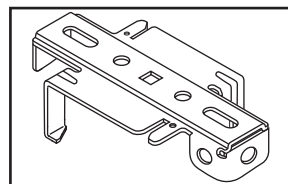

Support Bracket Part # 71865

- Helps support rails for 10' doors and higher.

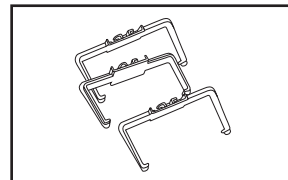

Wire Holder Kit Part # 86141

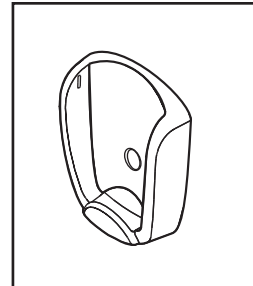

MINI Transmitter Mounting Plate Model # ML-920

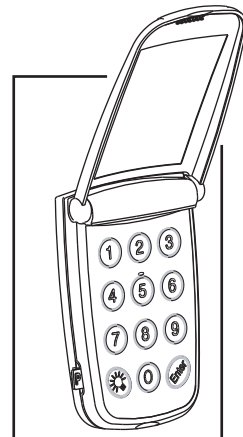

Wireless Keyless Entry System Model # M3-631

- Permits control of garage door operator from outside without keys.
- 4-digit security PIN.
- Battery Included.
- Complete with mounting hardware.

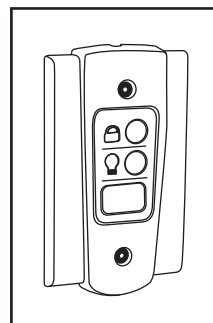

Wall Control Panel Model # M3-543

- Provides control buttons for Light and Vacation/Lock function.
- Illuminated door Pushbutton for easy locating in dark.
- Mounting hardware and wire included.

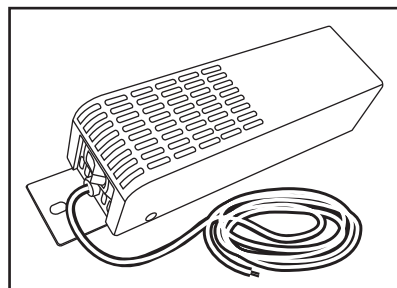

Door Lock - Locmatic G20 Part # 82783

- The Locmatic G20 is an automatic deadbolt locking system that provides additional security every time the garage door closes

6. OPERATOR PACKAGE CONTENTS

The following items are included with your Garage Door Operator (GDO). All hardware components are located in the GDO carton. The accessories are packaged with their respective hardware in separate packs for ease of identification and use.

Items shown not actual size.

Fig. 4

M4900e OPERATOR

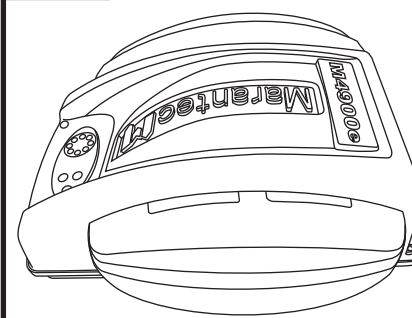

Two 2-Channel Mini Transmitters

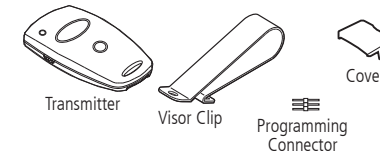

Garage Door Operator Manual and Safety Labels

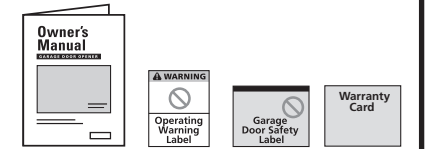

Wall Control Panel (with hardware kit)

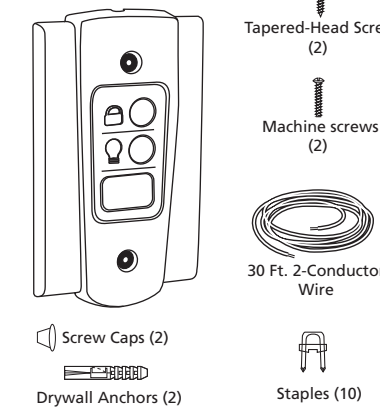
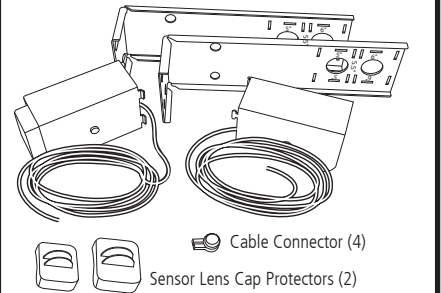
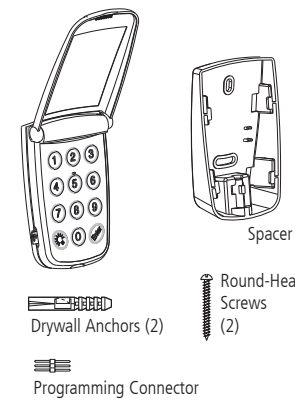

Photo Eye Sensor Safety System (with accessories)



Wireless Keyless Entry System (with hardware kit)



Wire Holder Kit

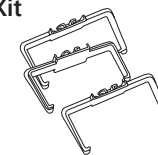

Extension Bracket Kit (with hardware)

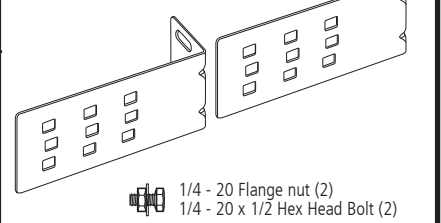

Hardware Kit

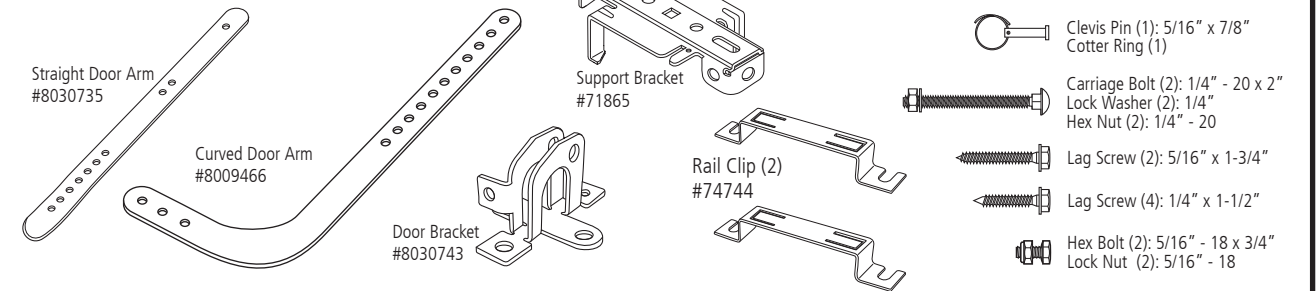
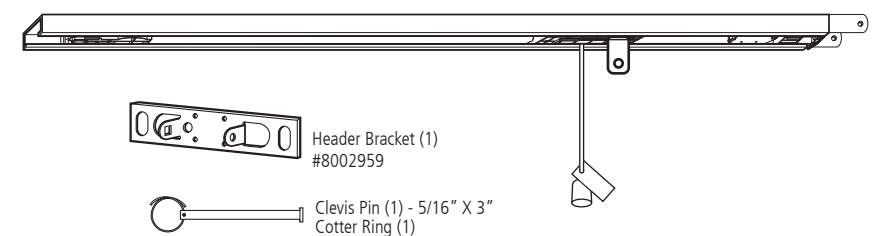

Fig. 5

RAIL ASSEMBLY



7. IMPORTANT INSTALLATION INSTRUCTIONS



IMPORTANT INSTALLATION INSTRUCTIONS TO REDUCE THE RISK OF SEVERE INJURY OR DEATH:

1. READ AND FOLLOW ALL INSTALLATION INSTRUCTIONS.

2. Check with the door manufacturer to determine if additional reinforcement is required to support the door prior to installation of the garage door operator.
3. Install garage door operator only on a properly balanced garage door. An improperly balanced door could cause serious injury. Have a qualified service person make repairs to garage door cables, spring assemblies, and other hardware before installing the operator.
4. Remove all ropes and disable all locks connected to the garage door before installing operator.
5. If possible, install the door operator 7 feet or more above the floor. Adjust the emergency release cord so that knob hangs 6 feet above the floor.
6. Do not connect the operator to source of power until this manual instructs you to do so.
7. Locate the wall control panel: (a) within sight of door, (b) at a minimum height of 5 feet above the ground so small children cannot reach it, and (c) away from all moving parts of the door.
8. Place the Operating Warning Label next to the wall control panel in a prominent location. Affix Safety Label on inside of garage door. The Emergency Release Tag must remain on the emergency release cord.
9. After installing the operator, test Safety Reversal System. Door **MUST** reverse when it contacts a 1-1/2 inch high object (or a 2x4 laid flat) on the floor.

For Important Safety Instructions see page 22.

Fig. 6

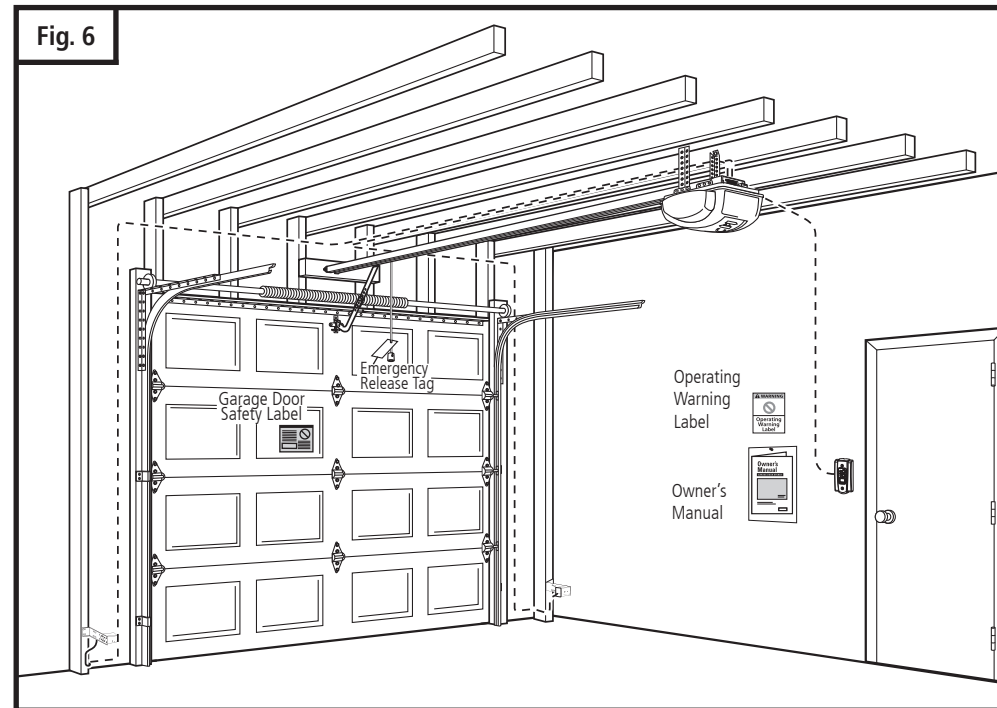

Shown on the right is an overall view of a completed garage door operator system installed on a sectional door. The arrangement is similar for a one-piece door (except for differences described later in this manual).

18. OPERATOR ASSEMBLY PARTS

Fig. 52

M4900e Operator
*Guide for part replacement only

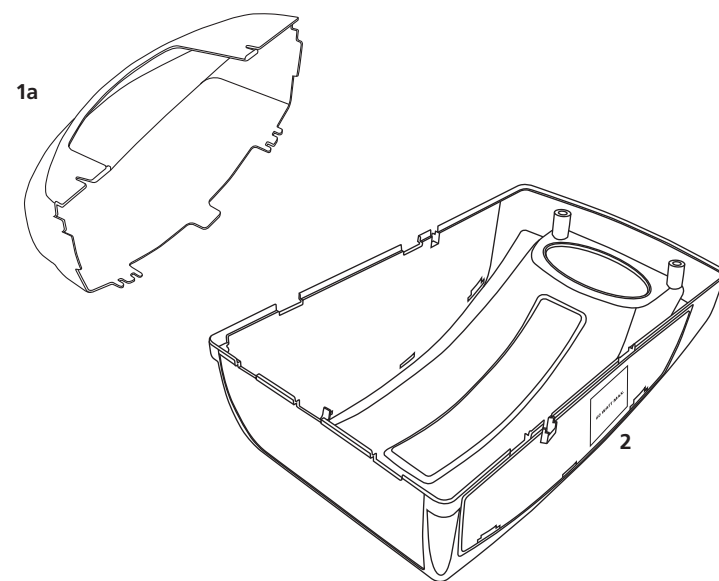
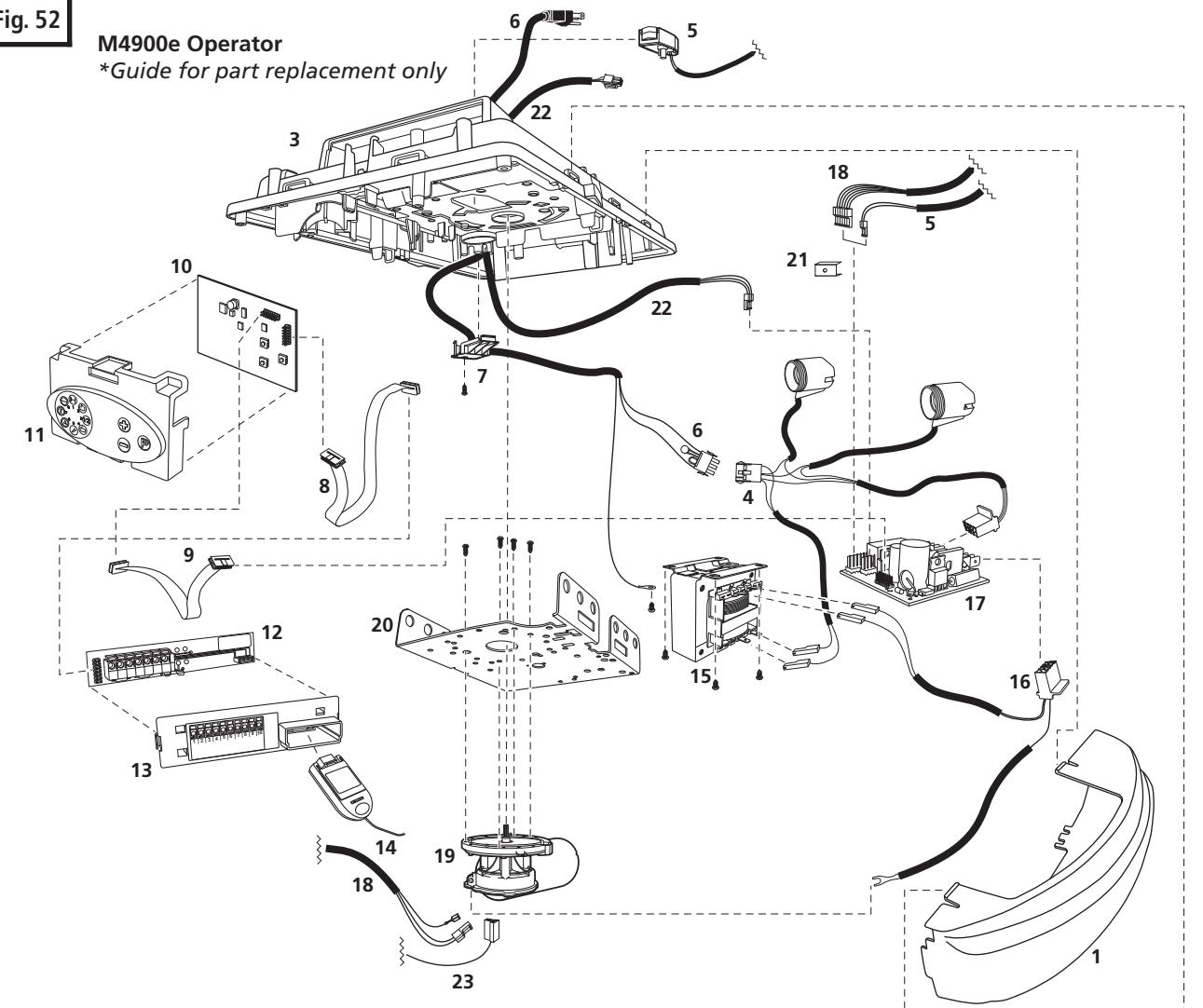

Item	Part #	Description
1	80349	Lamp Lens
1a	80348	Lamp Lens
2	80778	Housing with Labels
3	—	Chassis
4	78936	Wire Harness
5	8054389	Reference Switch
6	8030987	Power Cord
7	8007776	Strain Relief Cover
8	73557	Ribbon Cable
9	73109	Ribbon Cable
10	80821	Logic Board
11	79011	Control Panel
12	78938	Terminal Board
13	70014	Terminal Board Housing
14	78236	Modular Receiver
15	79067	Transformer
16	73699	Wire Harness (Motor / Transformer)
17	83364	Power Board
18	75350	RPM Sensor Harness
19	75365	Motor Assembly
20	—	Mounting Plate
21	60379	Clip
22	83388	Locmatic Harness
23	73698	Motor Harness

12. OPERATION OF YOUR OPERATOR (cont'd)

OPERATOR LIGHTS:

- The amount of time that the operator light(s) are "on" can be adjusted. Please refer to level 5 menu 4 in the "Advanced Settings"
- Lights will come on whenever operator is activated. The default factory setting for the light to stay "on" is 4 minutes and 15 sec., or until the Light On / Off button on the wall control panel is pressed, whichever is sooner.
- Lights can be turned on and off manually as described under operation of wall control panel.
- Lights will flash when the operator senses an obstruction either detected by the internal safety system or the photo eye sensors. To stop lights from flashing, remove obstruction and operate door normally. The fault light indicator will flash for the set light time "on" or for the factory default setting of 4 minutes and 15 seconds maximum.

13. MODULAR ANTENNA

To replace modular antenna simply pull out existing module located on the top of the chassis, and slide in the new one. It will make a clicking sound when the receiver module is locked into place. (See Fig. 48)

14. LOCMATIC READY

The control module harness on the same side as the operator power cord shown on figure 48A is provided for connectivity with the Locmatic System control module.

The Locmatic door lock system is an optional accessory sold separately.

15. HOMELINK® TRANSCEIVER

Before you can use your car's HomeLink® device to open a garage door you must transfer an active code from the transmitter to the HomeLink® Universal transceiver. (Reference - HomeLink® Manual) (See Fig. 49)

16. BELT DRIVE ASSEMBLY

See Fig. 50 for the belt rail assembly.

17. TENSION ADJUSTMENT

Your preassembled rail comes with the tension adjusted to factory specifications. There should be no need for further adjustment. However, if exposed or subjected to unusually harsh operating conditions, the tension may need to be readjusted during the life of the operator.

Check Proper Tension:

- Release trolley from belt connector, then examine the setting of the tension adjustment at the header end of the rail.
- Proper tension is set when the tension nut is tightened just enough so that the washer will be spaced approximately 21mm or 13/16" from the rail end-plate. See Fig. 51.
- If the gap between the washer and the rail end-plate is too big or too small, the tension needs to be adjusted.

Adjust the Tension:

- To increase the tension and tighten the belt, turn the tension nut clockwise with 1/2" or adjustable wrench until the washer is spaced properly from the rail end-plate. See Fig. 51.
- Once the washer is spaced correctly, any additional tightening will overtighten the belt and may cause damage to the system.
- To loosen the tension, turn nut counterclockwise.
- Reattach trolley.

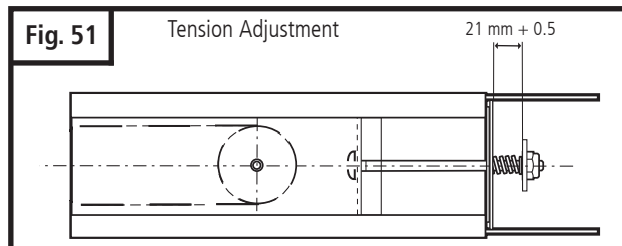
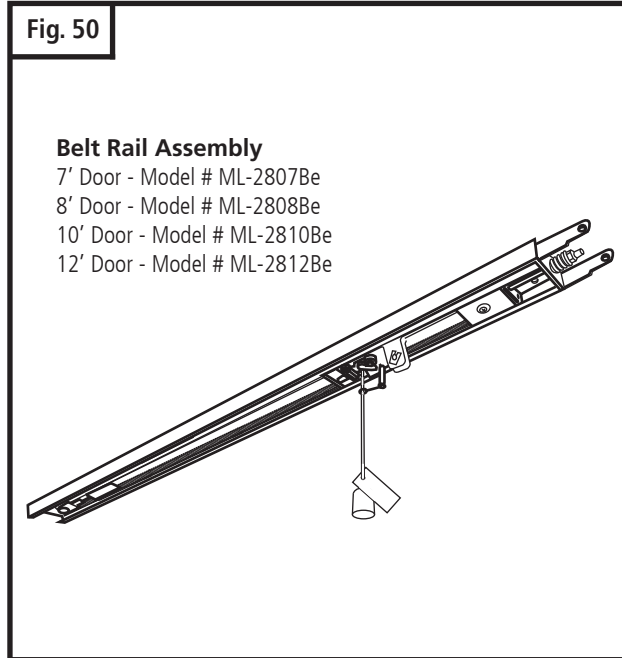
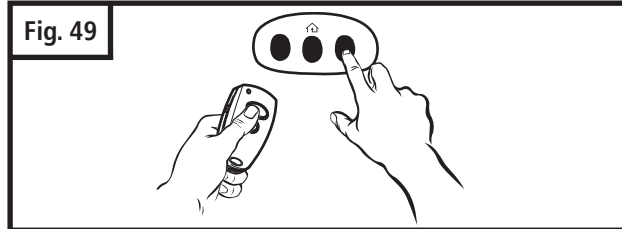
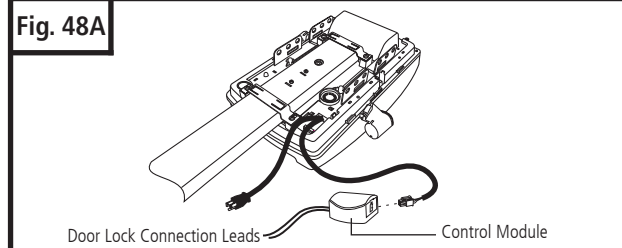
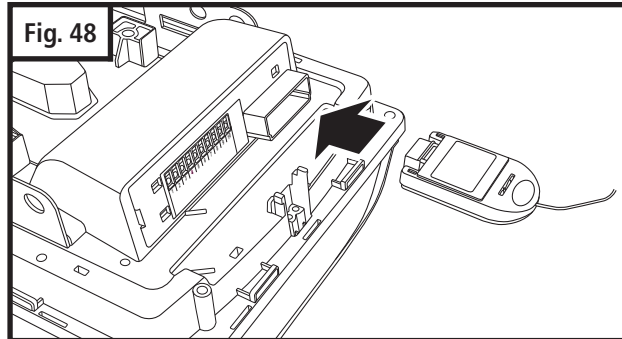

8. INSTALLATION STEPS

Unpack operator and one-piece preassembled rail and prepare hardware components for installation. Identify a sound structural support on header wall above garage door for header bracket mounting. See Fig. 8. If appropriate header does not exist, replace or install a new support using a 2x4 or 2x6 board. Fasten it securely using lag screws (not provided) to structural supports of garage.

8-1. ATTACH RAIL TO OPERATOR HEAD

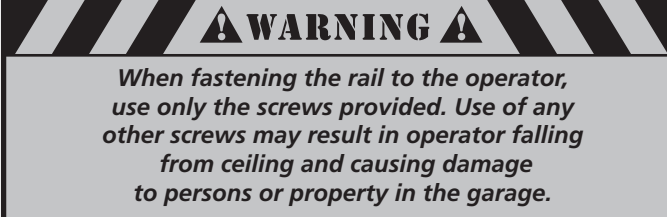

- Position door operator head with control panel facing front of garage. Rest operator head on cardboard or protective surface on floor so operator does not get scratched. Chassis side of operator (with motor shaft sticking out) facing up.
- Position rail onto operator chassis by lining up rail sprocket opening with motor head shaft (Fig. 7A). Make sure shaft engages teeth inside rail sprocket. Press rail down firmly onto shaft and operator chassis. DO NOT HAMMER.
- Position 2 "C" brackets over rail and onto chassis. Flanges on "C" brackets **MUST** fit into cutout area on chassis (Fig. 7B).
- Insert screws (6 x 14) through bracket holes and into chassis holes, and tighten screws firmly to hold rail to head (Fig. 7C).

8-2. MEASURE AND MARK DOOR AREA

Before starting your installation, the door and the header above the door must be measured and marked. This way, the appropriate brackets can be mounted at the correct locations avoiding installation and operating difficulties later.

MARK VERTICAL CENTER LINE:

- Measure door width, then locate the center point (Fig.8).
- Mark a vertical line on the upper half of your door, on the top edge of your door, and on the header, through the center point.

MEASURE DOOR'S HIGHEST TRAVEL POINT:

- Open door to its highest travel point and measure from the garage floor to the top of door (Fig.9).
- Write down this distance.
- Add 1-1/2" to the door travel height (measured above).

MARK HORIZONTAL LINE FOR HEADER BRACKET LOCATION:

- Close door and measure the required distance (determined above) from the garage floor to the header.
- Mark a horizontal line, intersecting the vertical center line, on header. This is the position at which the bottom of the header bracket should be installed.
- In case of minimal clearance above the door, the header bracket may be mounted to the ceiling. In this case, extend the vertical center line onto the ceiling, and mark a horizontal line on the ceiling no further than 4" from the header wall. The header bracket should be mounted no farther than this distance from the header wall.

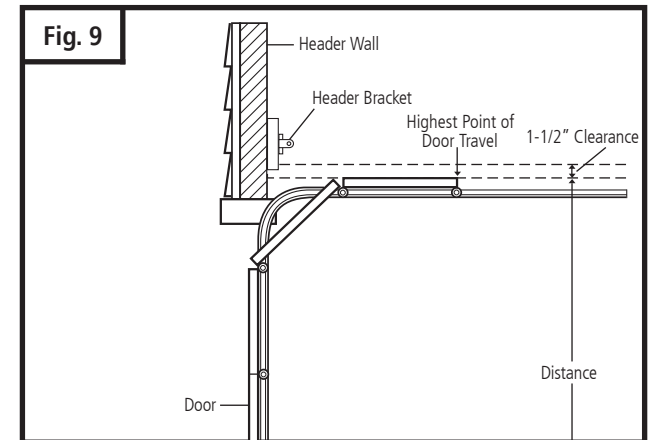
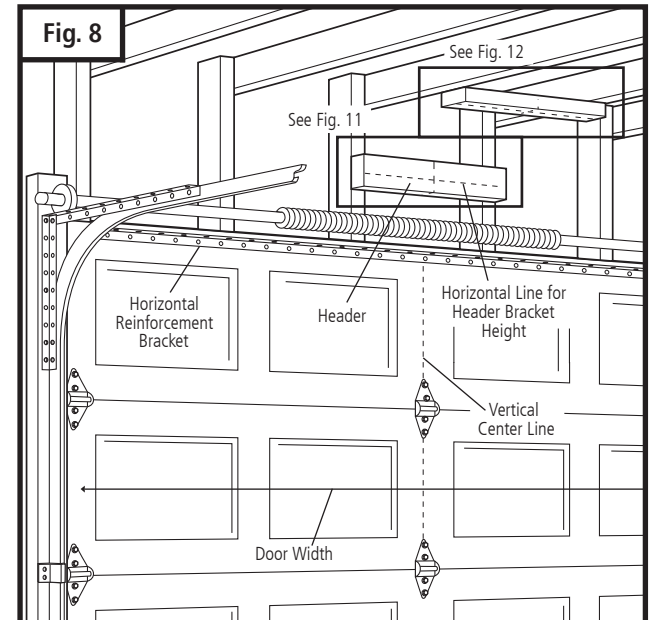
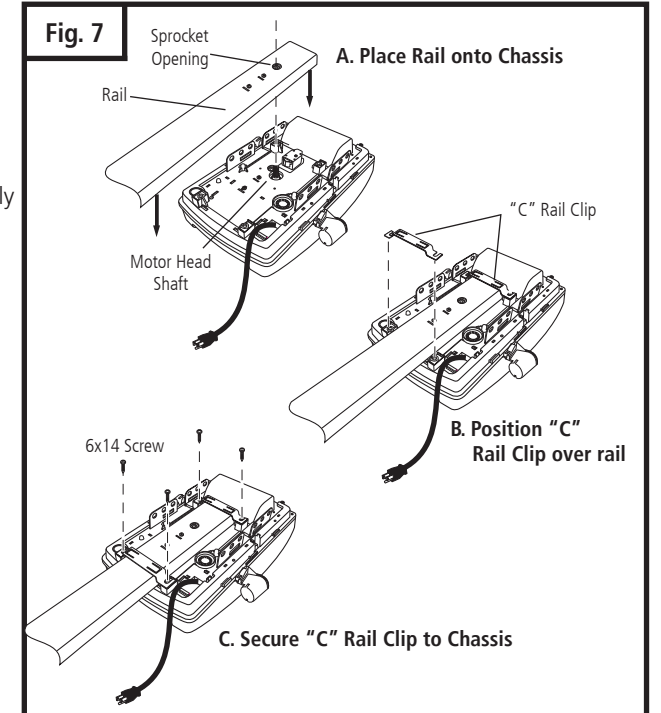

8-3. INSTALL DOOR BRACKET TO DOOR

Wood Sectional Doors (Fig. 11)

- Position door bracket (Fig. 10) along vertical center line of door with pin hole facing top of the door and top edge of the bracket 4" to 5" below top edge of the door, or roughly at the same height as top rollers on the door.
- Mark locations of securement holes through door bracket.
- Drill two 1/4" holes through door for securement of door bracket.
- Insert carriage bolts (1/4" x 2-1/2") from the outside through door and bracket, then secure with lock washers and nuts from the inside.
- Tighten nuts firmly.

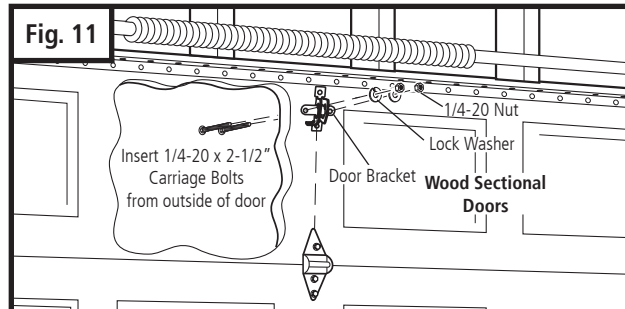
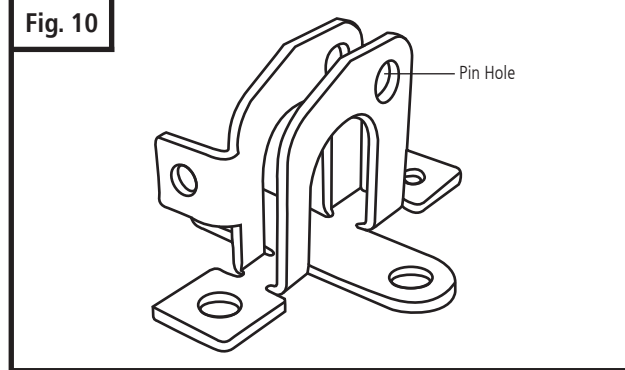

8-4. INSTALL HEADER BRACKET

WARNING

If the header bracket is not rigidly fastened to a sound structural support on the header wall or ceiling, the safety reverse system may not work and could cause serious injury or death. DO NOT move or adjust springs or garage door hardware, as these parts are under extreme tension and could cause injury or death.

- Remove and save clevis pin from header bracket assembly.
- Mark pilot holes location on header through header bracket holes where lag screws will be inserted. See Fig. 12 for which header bracket holes to use.
- Drill 3/16" pilot holes into header.
- Install bracket with lag screws (5/16 x 1-3/4") provided.
- Tighten lag screws firmly.

NOTE: Follow the same procedure if header (shown in Fig. 8) runs vertically instead of horizontally and is the only option for mounting header bracket to header wall. In case of minimal clearance above the garage door, the header bracket may be mounted to the ceiling. Follow the same steps above to ensure a sound surface for mounting.

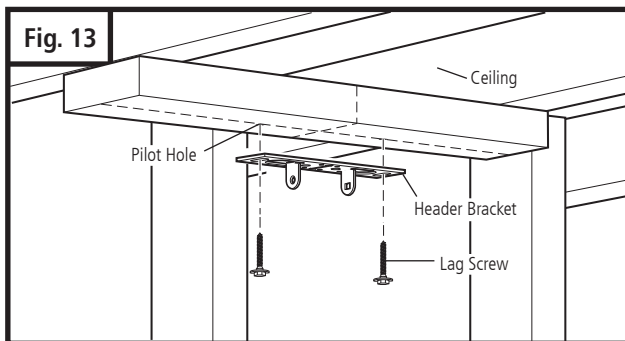
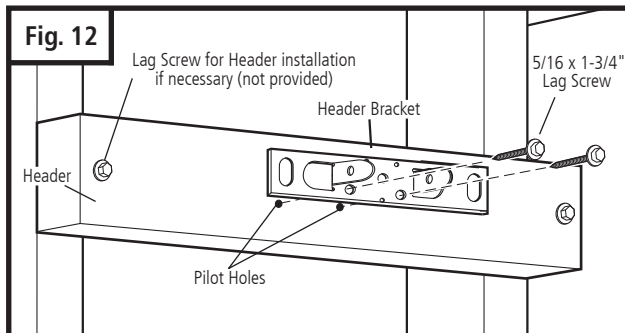

11. WIRELESS KEYLESS ENTRY SYSTEM (cont'd)

REPLACING THE BATTERIES (Fig. 46)

- Turn counterclockwise the key on the bottom of the spacer and remove the Keyless Entry System from the spacer.
- Release the backplate of the Keyless Entry System.
- Remove old batteries.
- Replace with 2 new 3V batteries, CR 2032. Match polarity designation. Test operability. (Keyless Entry System is designed to remember all previously programmed codes and PINs while battery is being replaced).
- Replace the backplate.

For protection of keypad, keep cover closed when not in use.

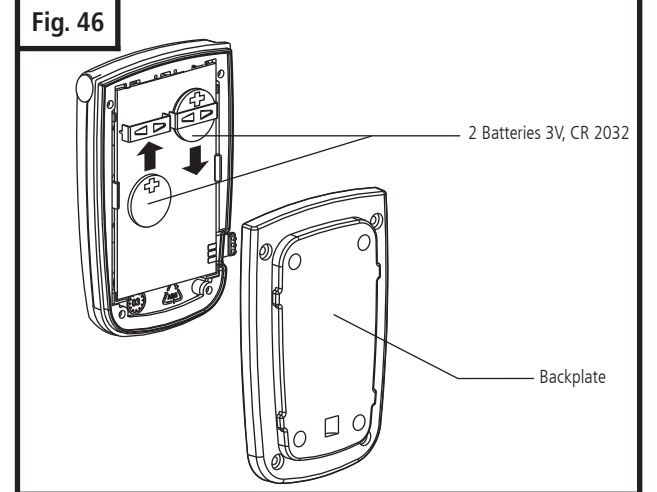

12. OPERATION OF YOUR OPERATOR

Your operator can be activated via any of the following, depending on which accessories your operator system has:

- Remote Control Transmitter
- Wall Control Panel
- Keyless Entry (optional accessory)

REMOTE CONTROL TRANSMITTER:

- To open or close garage door, press and hold button (Transmitter has an indicator light that will illuminate). See Fig. 47A. When garage door begins to move, release button.
- To stop garage door during travel, press and hold button until door stops, then release button.
- To resume garage door travel after stopping, press button again. Door begins to move in the opposite direction.

WALL CONTROL PANEL:

- The Door Pushbutton will light when Wall Control properly connected (if it does not light up, review section 8-11. "Install Wall Control" on page 15 or refer to "Having a Problem" on page 33). To open or close garage door, press and hold Illuminated Door Pushbutton. See Fig. 48. When garage door begins to move, release button. To stop garage door during travel, press and hold button until door stops, then release button. To resume garage door travel after stopping it, press button again. Door begins to move in the opposite direction.
- The Light On / Off button can be used to turn lights on or off.

NOTE: The Light On / Off button must be pressed twice, in order to turn the operator light(s) off after a door cycle (activation).

When using the light On / Off button, the automatic timer is ignored, and the lights will remain on until the button is pressed again, or until the operator is activated and the automatic timer begins again.

- The Lock/Vacation button can be used to lock out all remote control transmitters. The door can still be activated by wall control panel or keyless entry system. Press and hold Lock/Vacation button for 2-3 seconds. Release button. Illuminated Door Pushbutton will flash continuously while lock mode is active. To unlock operator, press and hold Lock/Vacation button for 2-3 seconds.

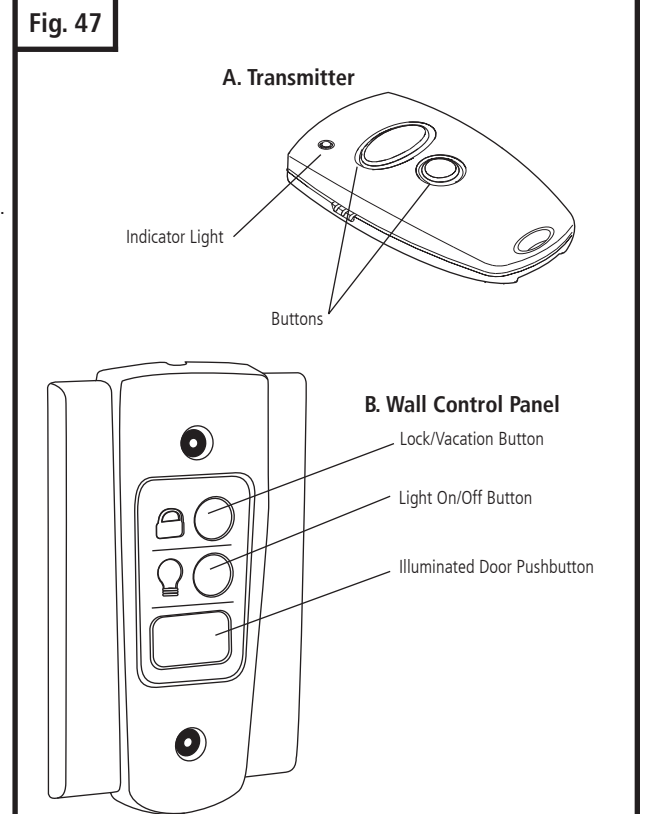

Important Note: If the vacation lock mode is engaged.

By pressing and holding the light button or the door activation button for one second or longer will disengage the vacation lock mode.

11. WIRELESS KEYLESS ENTRY SYSTEM

A: SETTING UP YOUR PERSONAL IDENTIFICATION NUMBER (PIN) AND TRANSFERRING THE CODE (Fig. 45A) Transferring the Code to the Keyless Entry System from Transmitter:

- Open the terminal area and connect the Keyless Entry System to the active transmitter using the programming connector.
- Press and hold the transmitter button you use to open and close your garage door. On the Keyless Entry System, press the ENTER button. The keypad illumination turns on.
- Input any new 4-digit PIN of your choice. Press the ENTER button again. Keep the transmitter button pressed until the LED on the Keyless Entry System blinks rapidly.
- The Keyless Entry System has now learned the code from the transmitter, and stored it under the PIN that you entered. Remove the programming connector and close the terminal area.

B: KEYLESS ENTRY SYSTEM MOUNTING (Fig. 45B)

- Choose location for mounting your Keyless Entry System.
- Using mounting holes at top and bottom of the spacer as a guide, mark hole locations and then drill two 1/16" pilot holes.
- Secure spacer to the mounting surface with the (2) screws provided. For mounting surfaces that are not made of wood, alternate anchoring means may be needed.
- Snap the Keyless Entry System into the spacer.
- Turn clockwise the key on the bottom of the spacer using a coin to lock the Keyless Entry System.

C: USING KEYLESS ENTRY SYSTEM

STORING MORE THAN 1 PIN FOR SAME CODE

- It is possible to store up to 3 different PINs for the same code for use by different individuals.
- Follow the same steps as described in Step A. Repeat the procedure for each PIN, using the same transmitter each time. This will store the same code under 3 different PINs.

STORING A TEMPORARY PIN

- A temporary PIN can be stored which will permit operation for 3 times only.
- Press and hold "button 1" on the keypad for 3 seconds until the LED on keypad blinks rapidly. Enter your original PIN followed by the ENTER button.
- Enter a temporary 4-digit PIN of your choice followed by the ENTER button.
- The LED on the keypad will illuminate for 2 seconds, then the Keyless Entry System will shut off and the keypad illumination will go out. Keyless Entry System is now ready for use again.
- To use Keyless Entry System with the newly stored temporary PIN, enter the 4-digit temporary PIN followed by pressing the ENTER button. This can be done 3 times, after which the temporary PIN will be automatically erased.

STORING MORE THAN 1 CODE TO CONTROL MORE THAN 1 GARAGE DOOR OPERATOR

- The Keyless Entry System may be used to control up to 3 different garage door operators, each with a different code.
- For code #1 and #2 follow the same procedure as described in Step A. Enter a different PIN for each code.
- **For code #3 enter factory pre-programmed PIN 1-2-3-4, and then change this PIN to new PIN of your choice. Follow steps as described below.**
- To use the Keyless Entry System to open or close a specific door, simply enter the corresponding PIN for that door followed by pressing the ENTER button.

Fig. 45

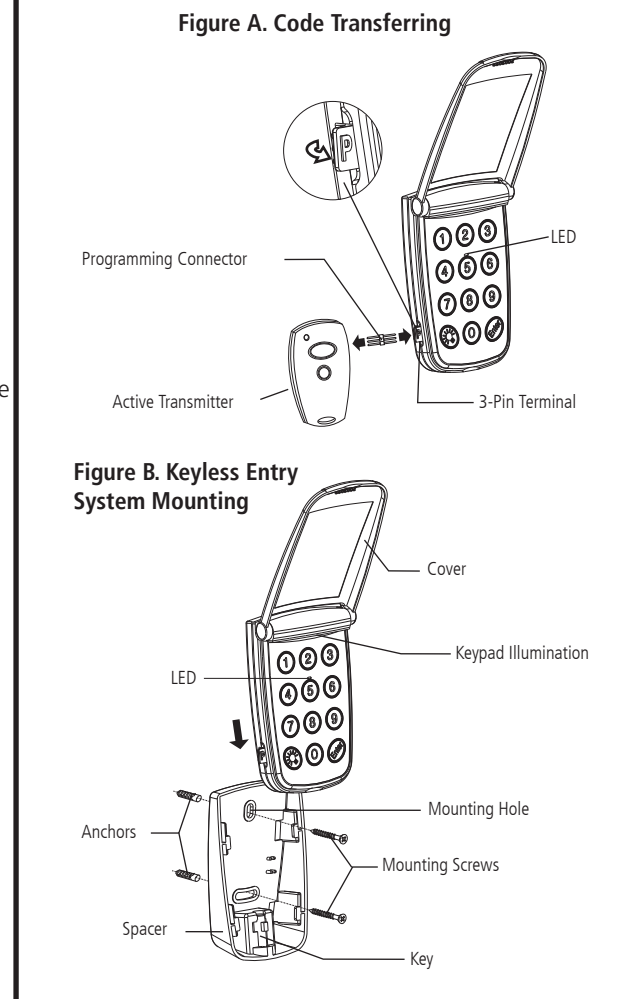

CHANGING THE PIN

- Press and hold "button 0" on the keypad for 3 seconds until the LED on the keypad blinks rapidly.
- Enter the PIN which is to be changed followed by pressing the ENTER button.
- Enter the new 4-digit PIN followed by pressing the ENTER button. The LED on the keypad will turn on (no flashing) for 2 seconds.
- The Keyless Entry System is now ready for use again with the new pin (Old PIN is no longer valid).

CLEARING THE MEMORY

- Press and hold the LIGHT button on the keypad for 3 seconds until the LED on the keypad blinks rapidly.
- Enter the PIN 9-9-9-9.
- Release LIGHT button. The memory is cleared. The LED on the keypad will illuminate for 2 seconds.

NOTE: After clearing the memory, the Keyless Entry System defaults to a random code and the PIN 1-2-3-4.

8-5. ATTACH RAIL TO HEADER BRACKET

- Support operator head slightly off the floor.
- Lift the opposite end of the rail up to the header bracket.
- Position rail end-stop within the openings in the header bracket. Insert header clevis pin (5/16" dia.) through header bracket and rail end-stop, then attach cotter ring to end of pin. (See Fig. 15)

8-6. POSITION OPERATOR FOR MOUNTING

Once rail is attached to header bracket, support operator on ladder, or use the assistance of another person to support operator high enough so door can open without hitting the rail.

- Open garage door to fully opened position, and place a 2x4 laid flat between the door and the rail. See Fig. 16. This provides an easy method of ensuring the correct mounting height of the operator.

8-7. MOUNT OPERATOR TO CEILING

WARNING
If not properly secured, the operator could fall and injure someone. Secure operator to structural supports or framing. Do not mount to drywall, plaster, or other such material.

A. Fasten Operator to ceiling

- Position operator head so that rail is lined up with center line of open door.
- Line up hanger brackets (not provided) with ceiling joists or framing to locate where brackets are to be fastened. See Fig. 17.
- Mark location for 5/16" lag screws (not provided), and drill two 3/16" pilot holes.
- Fasten hanger brackets to joists using lag screws.

Fig. 14

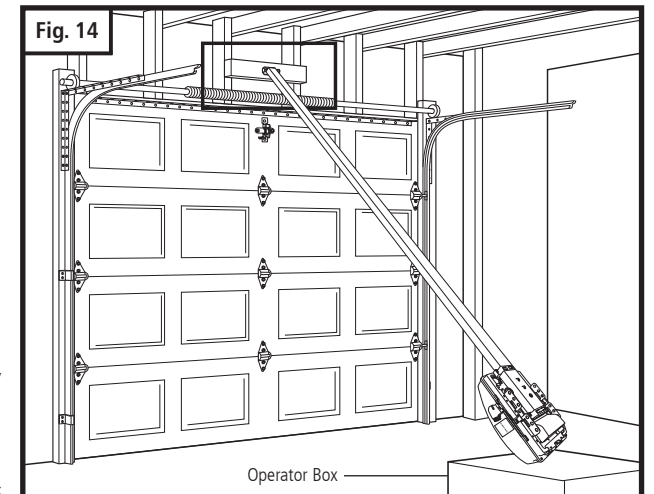

Fig. 15

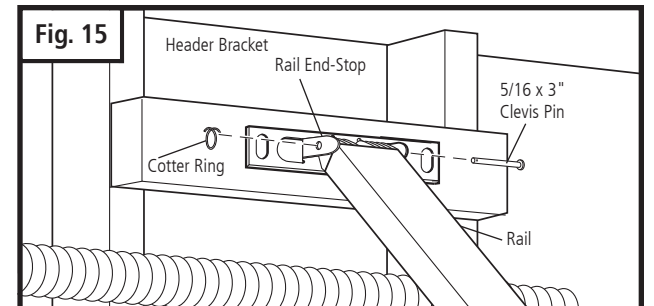

Fig. 16

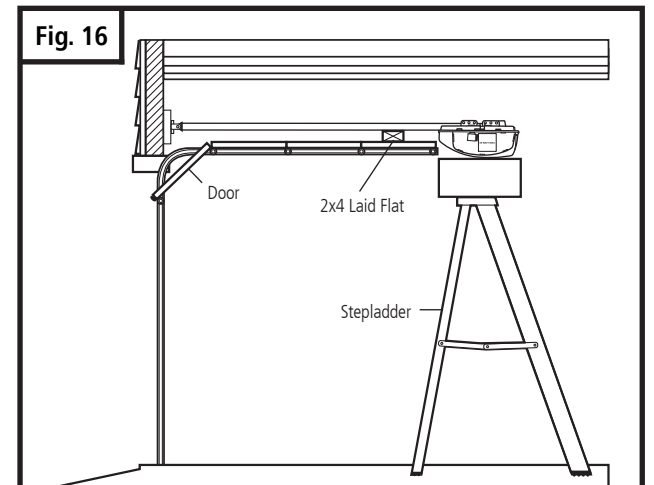
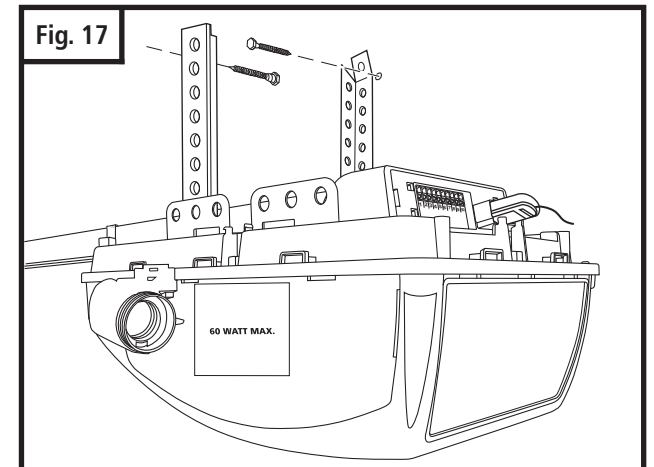

Fig. 17



8-7. MOUNT OPERATOR TO CEILING (cont'd)

- If garage framing supports are not visible, attach a length of perforated angle or a 2x4 to the ceiling, securing it to the hidden joists with lag screws long enough to fasten firmly to garage framing (extra hardware items not provided). Then, attach one end of hanger brackets to the angle or 2x4 mounted to ceiling. Attach other end of hanger brackets to operator's perforated angles. See Fig. 18 for an alternate mounting methods.
- Once operator is securely fastened in position, remove wood blocks and temporary supports and lower door. Check door for proper operation and clearance by manually moving door to full open and closed position. If door hits rail at any point, raise operator head slightly higher and re-mount in position.

B. Attach support bracket

- Measure the rail's overall span. Bracket is located on 1/3rd of the overall rail span from the door header bracket end. See Fig. 19
- Place support bracket over rail (close side) on a diagonal. Make sure support securement clamps clear rail sides.
- Secure bracket onto rail by twisting support bracket as indicated in Fig. 20.
- Attach mounting strap (not provided) to support bracket and secure by fastening it to the ceiling.

8-8. CONNECT ARM TO DOOR AND TROLLEY

- Make sure door is fully closed.
- Remove tape from rail holding straight door arm (sectional door only) and allow door arm to hang freely.
- Insert single hole side of straight door arm into trolley channel.
- Align straight door arm and trolley holes, then insert clevis pin through holes, and attach cotter ring to hold pin in place.
- Pull the manual release cord on the trolley to disconnect trolley from chain or belt connector. Slide trolley to position it about 4" away from the door.
- Position curved door arm into door bracket channel so that short end of arm will be attached to door bracket. See Fig. 21. Curved door arm should be attached roughly at the same height as the top rollers of the door.
- Align curved door arm and bracket holes, then insert clevis pin through holes. Attach cotter ring to hold pin in place.
- Position straight arm and curved arm to form an angle with the door (Fig. 22) and at least two sets of holes line up. Select two overlapping holes as far apart as possible and secure arms together with hex bolts (5/16-18) and lock nuts.

PULL EMERGENCY RELEASE KNOB TOWARD THE OPERATOR AT 45 DEGREE ANGLE TO LOCK TROLLEY, THEN MOVE DOOR MANUALLY UNTIL TROLLEY LOCKS WITH CONNECTOR INSIDE RAIL.

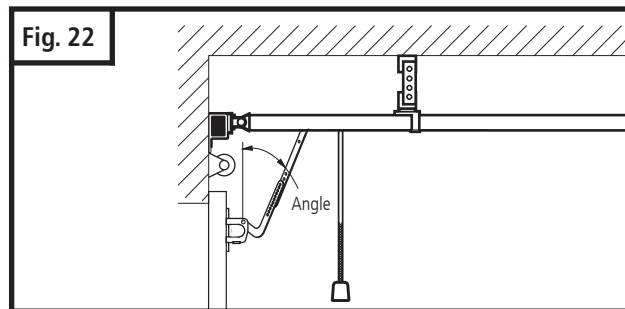
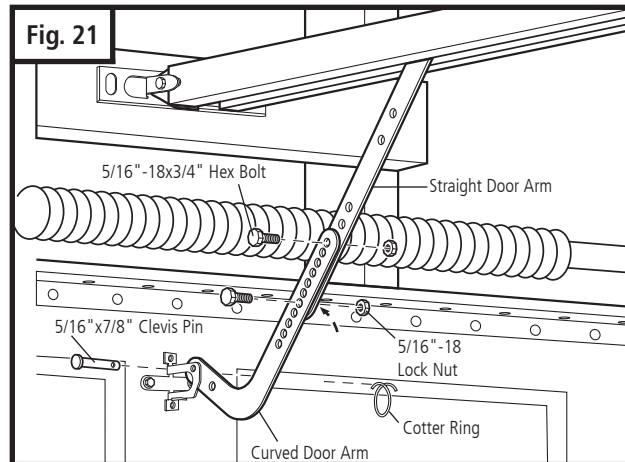
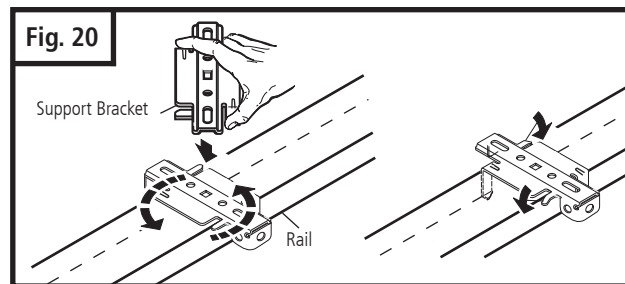
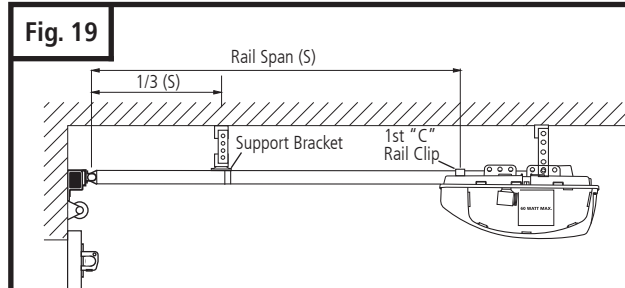
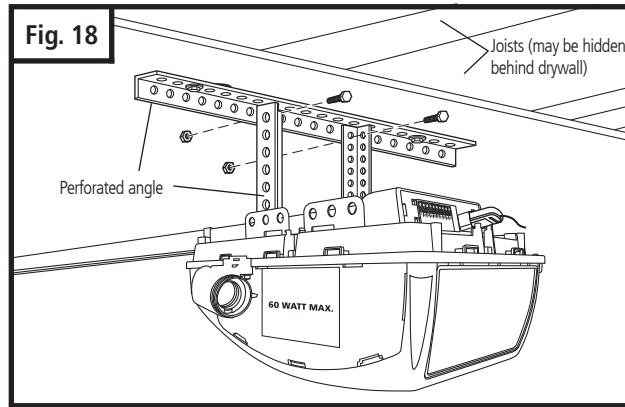

10. TRANSMITTERS

TRANSMITTERS (Fig. 39):

A family of state-of-the-art transmitters, each transmitter is custom encoded with installed battery. Offered in two styles to suit your personal preference.

- Mini (2-or 4-channel)
- Micro (3-channel) with keyring attachment.

TRANSMITTER MOUNTING:

The transmitters can be conveniently mounted inside your car using the visor clip or on the wall using the mounting plate.

Visor Clip (Fig. 40)

- Snap visor clip into transmitter.
- Affix assembly to visor.

NOTE: If you do not need the visor clip, install the visor compartment cover.

Mounting Plate (Fig. 41)

- Secure the mounting plate to area of preference using screw and anchor.
- Snap the visor compartment cover.
- Slide the transmitter into the mounting plate, which will hold it firmly in place.

MULTIPLE TRANSMITTERS (Fig. 42):

Each transmitter comes factory programmed with random codes. 2-channel transmitters have 2 different random codes, one per button, 3-channel transmitters have 3 different random codes and 4-channel transmitters have 4 different random codes, one per button. Transmitters that are purchased separately as accessories have random codes that must be changed in order to match the code of the "active" transmitter, which you are already using. Below are instructions for transferring an active code from a button on one transmitter to a button of your choice on another transmitter.

- Connect the transmitter with active code to the new transmitter using the programming connector. (Fig. 42)
- Press and hold the selected channel button on the transmitter with the active code.
- Press and hold the respective channel button on the new transmitter. The light in the transmitter initially starts blinking and then illuminates continuously after 1-2 sec. Code transfer is completed.
- Programming connector can be removed and both transmitters can now be used to operate the same operator.

NOTE: For multi-button transmitters, be sure to carry out this procedure for all the buttons you desire to use.

CHANGING THE CODE (Fig. 43):

The transmitter factory preset code can be changed as follows:

- Insert the programming connector into transmitter terminal.
- Short one of the outer pins of the programming connector with the middle pin.
- Press and hold the respective channel button. The light will blink rapidly for approximately 5 sec. Release the button after the light illuminates continuously. Code will change in approximately 2 seconds.
- Remove the programming connector.
- Once the transmitter code is changed, the operator must be recoded with the new transmitter code as described on the initial system set up page 16.

NOTE: For multi-button transmitters, be sure to carry out this procedure for all the buttons you desire to use.

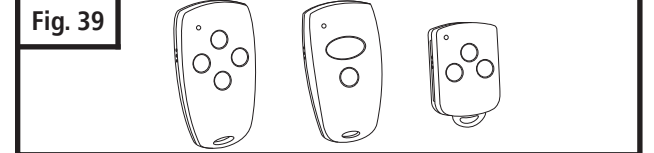

FCC Certified: This device complies with Part 15 of the FCC rules. Operation is subject to the following two conditions: (1) this device may not cause harmful interference, and (2) this device must accept any interference received, including interference that may cause undesired operation. Changes or modifications not expressly approved by the party responsible for compliance could void the user's authority to operate the equipment.

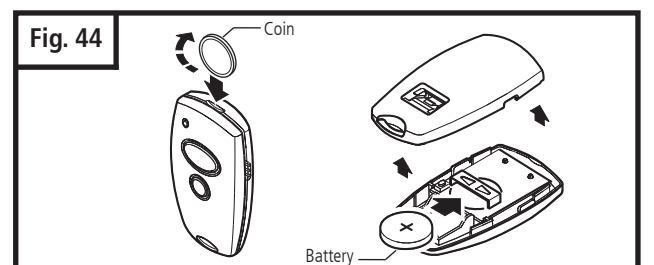
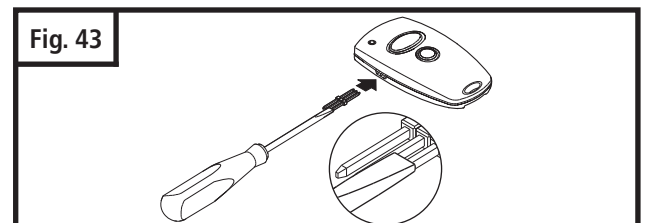
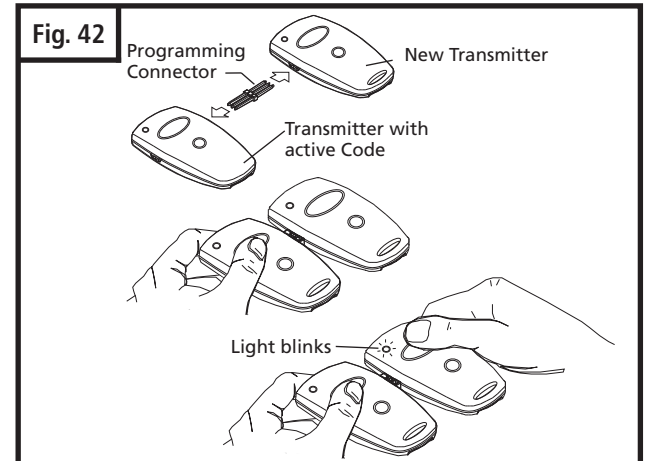
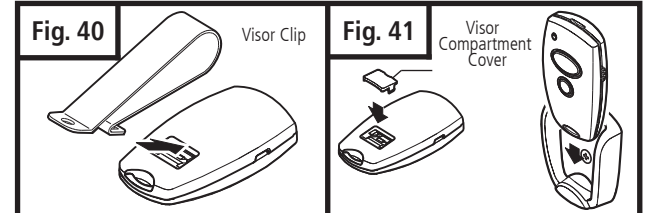

BATTERY REPLACEMENT (Fig. 44):

- Open the transmitter by using small coin.
- Insert a 3V battery (type CR2032) as shown.
- Close the transmitter.

NOTE: Replace batteries with same type only.

8-20. APPLY LABELS TO INSIDE OF GARAGE

Several important safety and instruction labels are included with your operator package. These labels must be posted inside your garage where they can be easily seen by all. We recommend installing them in the location shown in Fig. 6 on page 6. To affix the labels, peel off the protective backing, and stick onto smooth, clean surface. If labels don't adhere well to surface, use tacks (wood door only) or additional adhesive to securely affix in place. **DO NOT PAINT OVER ANY LABELS.**

8-21. ATTACH OWNER'S MANUAL TO WALL

It is important that the manual be stored where it can be referred to later in case adjustments need to be made, and / or new controls or accessories added. Store the manual in a safe, easily accessible location. We recommend you use an envelope with an eyelet to store the manual in the garage on a nail or hook on the wall near the wall control.

9. IMPORTANT SAFETY INSTRUCTIONS



IMPORTANT SAFETY INSTRUCTIONS TO REDUCE THE RISK OF SEVERE INJURY OR DEATH:

1. **READ AND FOLLOW ALL INSTRUCTIONS CAREFULLY.**
2. Never let children operate or play with door controls. Keep the remote control away from children.
3. Always keep the moving door in sight and away from people and objects until it is completely closed. **NO ONE SHOULD CROSS THE PATH OF THE MOVING DOOR.**
4. NEVER GO UNDER A STOPPED, PARTIALLY OPEN DOOR.
5. Test door operator monthly. The garage door **MUST** reverse on contact with a 1-1/2" high object (or a 2x4 laid flat) on the floor. After adjusting either the force or the limit of travel, retest the door operator. Failure to adjust the operator properly may cause severe injury or death.
6. If possible, use the emergency release only when the door is closed. Use caution when using this release with the door open. Weak or broken springs may allow the door to fall rapidly, causing severe injury or death.
7. **KEEP GARAGE DOORS PROPERLY BALANCED.** See Garage Door Owner's Manual. An improperly balanced door could cause severe injury or death. Have a qualified service person make repairs to cables, spring assemblies, and other hardware.
8. Disconnect the electrical power to the garage door operator before making any repairs or removing the housing cover.
9. **SAVE THESE INSTRUCTIONS** for future safety, adjustment, and maintenance purposes.

8-9. CHECK EMERGENCY RELEASE

The release cord with knob should be adjusted to hang 6 ft. above garage floor

To adjust:

- Slide knob up on cord.
- Tie new knot at correct height.
- Cut excess cord, leaving approximately 1" after knot.
- Heatseal end of cord with match or lighter to prevent fraying.
- Slide knob back into place.

WARNING

Use extreme care when pulling release knob. **DO NOT** use knob to pull door open or closed. Except for emergency situations, use knob only when door is closed.

If the door is in the open position, use extreme care when using the release.

Use emergency release to disconnect the door if the power is out. This allows the door to be moved manually up and down independent of the operator motor. It should also be used if for some unforeseen reason the door strikes a person or object during its travel and does not automatically reverse off the obstruction.

To release door—pull emergency release knob toward the door at approximately 45 degrees. (Fig. 23)

Prior to re-engaging door, ensure that all obstructions are removed and door is operating properly manually. Before re-engaging trolley with a belt connector, pull knob toward the operator at approximately a 45 degree angle. Now the door can be reconnected by moving it manually and bringing it into position when the connector is inside of the trolley.

8-10. INSTALL LIGHT BULBS AND LENSES

CAUTION

To prevent possible **OVERHEATING** of the end panel or light socket:

- Use **ONLY A19 size standard neck incandescent light bulb(s).**
- **DO NOT use short neck or specialty light bulbs.**
- **DO NOT use halogen light bulbs.**
- **DO NOT use a bulb with a rating higher than 60 Watts (W). A stronger or larger bulb may result in fire or damage to the opener.**

To prevent possible **radio frequency (RF) signal interference** **DO NOT use compact fluorescent lamp (CFL).**

- Install a maximum 60W standard neck A19 size incandescent bulb (not provided) into lamp socket(s).
- Install lamp lens(es). Lenses are not interchangeable, the design is left / right orientation dependent. See Fig. 24A.
- Line up lamp lens tabs with slots in housing and snap securely into place. Repeat same procedure with second lamp lens on the opposite side.
- Line up lamp lens tabs with corresponding slots in chassis.
- To remove lamp lens, pull lamp lens to unsnap from housing and chassis.

Fig. 23

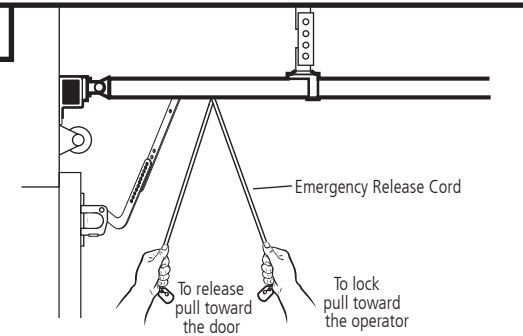
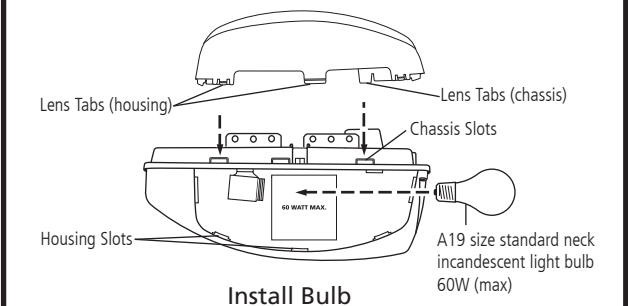

Fig. 24

NOTE: Use only A19 size standard neck incandescent light bulbs. The use of short neck or specialty light bulbs may overheat the endpanel or light socket.

WARNING

To prevent possible serious injury and damage to the operator when replacing the light bulbs:
• **Disconnect ALL electric and battery power BEFORE performing ANY service or maintenance.**



Install Bulb

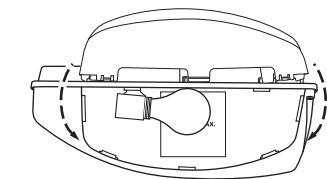

Snap lamp lens tabs into slots in chassis

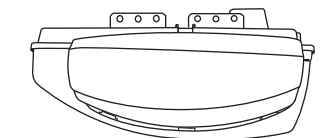

Hinge lamp lens downward line up tabs with slots in housing, and snap into place.

Fig. 24A

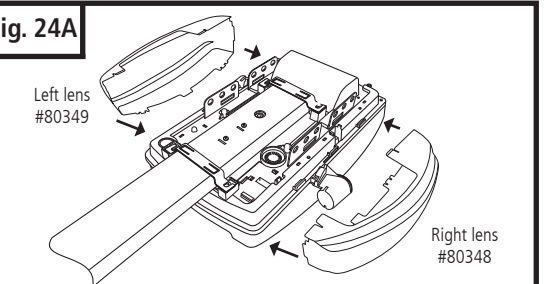

8-11. INSTALL THE PHOTO EYE SENSOR SAFETY SYSTEM

CAUTION

To provide the maximum amount of protection, the photo eye sensors must be mounted between 3.5" and 5" above the floor. See Fig. 26.

CONNECTING WIRES TO THE PHOTO EYE SENSORS SUPPLIED WITH SEPARATE WIRE BUNDLE AND PREWIRED GARAGES (if required). Fig. 25

- Separate 2" of the double wire from each photo eye sensor into two single wires.
- Connect the solid color (white) wires leads from each sensor together with the wire (white) leads to operator quick-connect terminals. Repeat the same procedure for the sensors stripe wire (black / white). Use the cable couplers shown in Fig. 25 for connections between sensor wire and installation wires.
- Run wires along the wall and the top of the rail assembly to the operator. Use the three wire holders to secure wires. See Fig. 25A.

MOUNTING THE PHOTO EYE SENSOR BRACKETS TO WALL:

- Locate the mounting position for brackets (bracket can be mounted in any position as long as photo eye beam will have a clear path from one side of door to other side after mounting).
- Use the bracket mounting holes as a template to locate an drill (2) 3/16" diameter pilot holes on both sides of the garage door as shown in Fig. 26.
- Secure the bracket with 1/4" x 1-1/2" lag screws provided as shown in Fig. 26.

MOUNTING THE PHOTO EYE SENSORS TO MOUNTING BRACKET. Fig. 27

- Install the sensors to the mounting bracket by inserting bend clips of sensor bracket through the vertical slot on mounting bracket. See Fig. 27A.
- Insert straight clips through other set of vertical slot on the mounting bracket.
- Twist one of the straight clips slightly to lock the sensor in place once inserted through vertical slot on the mounting bracket. See Fig. 27B.
- Repeat the above procedure for the other sensor.

NOTE: To provide maximum protection, the photo eye brackets must be mounted between 3.5" and 5" above the floor, but not exceeding 5". The sensors must be installed with the wire terminal pointing downward towards the garage floor.

EXTENSION BRACKETS INSTALLATION. Fig. 28

- Locate the mounting position for extension bracket as shown in Fig. 26.
- Secure the bracket to the wall with two lag screws provided.
- Attach photo eye bracket to extension bracket and secure with hardware provided.
- Repeat process for the other bracket.

SENSOR PROTECTION Fig. 28A

- Before performing maintenance work in garage, such as, power washing, painting, and other tasks; protect sensors with provided sensor caps.

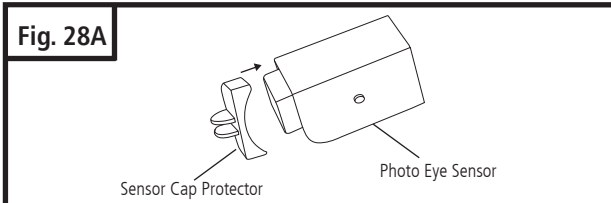
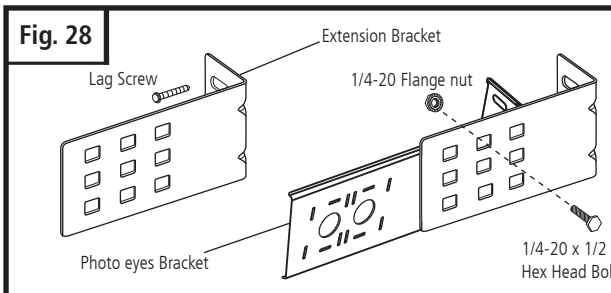
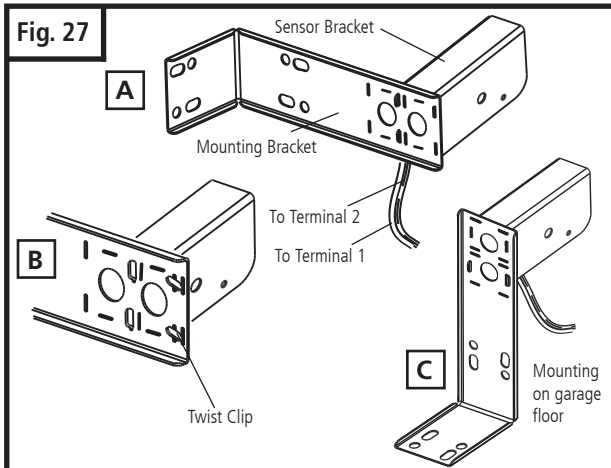
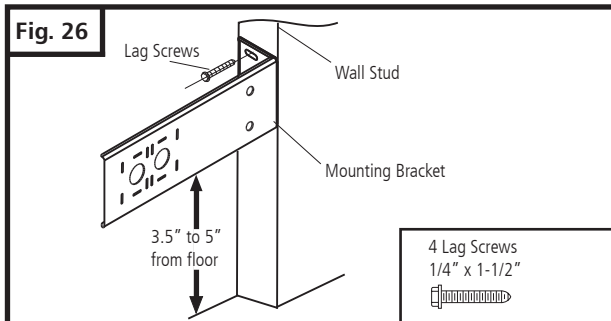
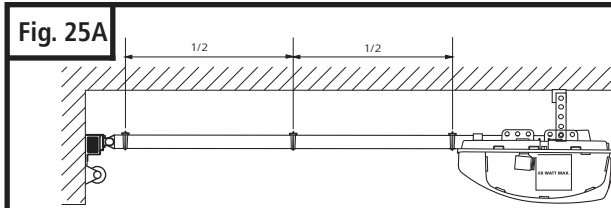
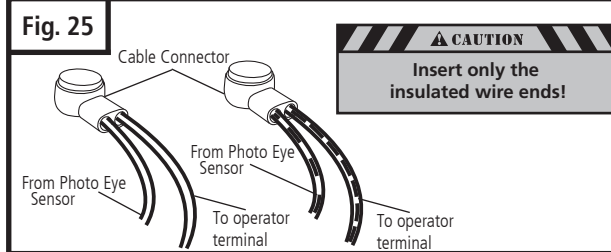

8-18. TEST SAFETY REVERSAL

The safety reversal function of your operator is an extremely important feature of your operator. Testing this function ensures the correct operation of your operator and door.

The reversal system test should be performed:

- Once per month.
- Anytime the travel or force limits are reset or changed.

CAUTION

Once the adjustments have been set and the door has been run up and down twice uninterrupted for the operator to "learn" the new settings, you must test the reversal system for proper operation.

- Place a 1-1/2" high rigid object (or a 2x4 board laid flat) on the floor directly in the path of the door. See Fig. 36.
- Start the door in the downward direction and watch what happens.
- When door contacts the object (or 2x4), it should stop, reverse, and automatically return to the fully opened position.
- If the door does not reverse, reset the down travel limit so that the door travels slightly further down in the closed direction. Then, retest the unit as described above.
- If the door still does not reverse, disconnect your operator and call a service person.

8-19. ALIGN AND TEST PHOTO EYE SENSORS

PHOTO EYE SENSORS ALIGNMENT:

The photo eye sensors maintain an invisible, unbroken beam between each other. See Fig. 38.

NOTE: Sensor alignment must be done with the door in the closed position in order to ensure proper visibility of the sensor indicator LED.

- When the photo eye system is connected to the operator and the power is on, the green light on the transmitter sensor flashes, if the sensors are not aligned. When the sensors are aligned, the green light on the transmitter sensor will turn steady. See Fig. 38.
- Sensors must be installed parallel to the door plane and make sure the sensors are facing each other.

AFTER THE SENSORS HAVE BEEN PROPERLY ALIGNED, MAKE SURE THAT THE SYSTEM OPERATION AND SAFETY TESTS OUTLINED BY THE GARAGE DOOR OPENER MANUFACTURER HAVE BEEN VERIFIED.

SAFETY TEST:

Photo eye sensors installed on opposite sides of your door opening are intended to detect a person or object in the path of the door and prevent the door from moving downward. The following steps will determine if the system is functioning properly:

- Open door using the operator's transmitter or wall control.
- Place a box or other object in the path of the door so it breaks the photo eye beam. See Fig. 38A. Red indicator light on receiver should go out.

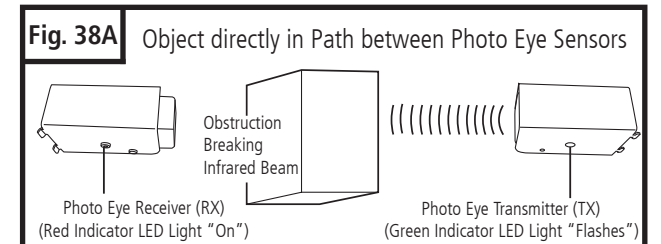
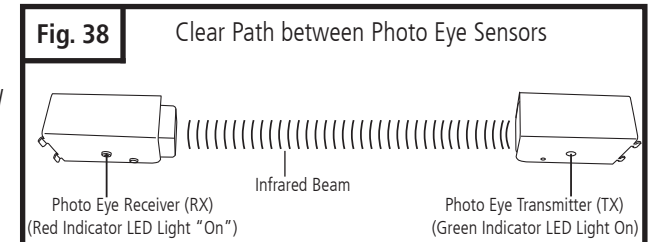
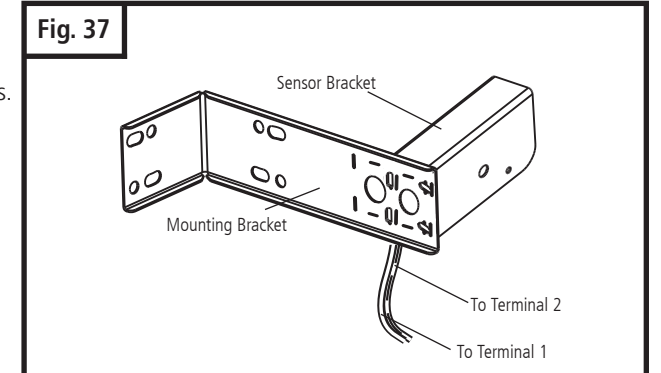
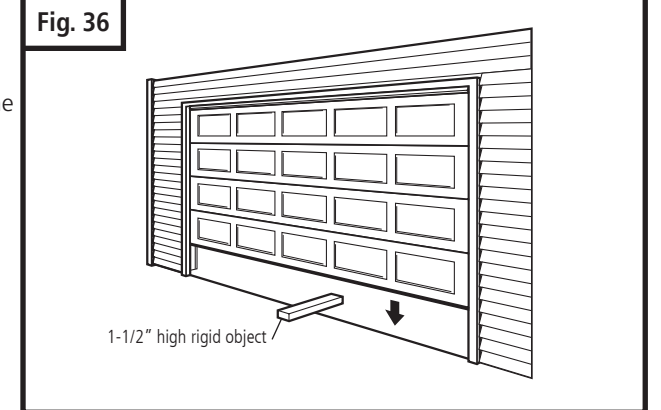

- Press and release the wall control button. The door should not move in the down direction. LED# 7 and #8 on the operator will flash. If this does not happen, disconnect operator and call for service.
- To reset operator, remove the obstruction and operate the door normally.
- If photo eye sensors are not aligned or are damaged, door can only be closed by pressing and holding wall control button until door is fully closed.

8-17. ADVANCED SETTINGS (cont'd)

Level 5: Functions overview

Level 5 - Special Function																
	1	2	3	4	5	6	7	8	9	10	11	12	13	14	15	16
Menu 4: Operator Light "ON" Timer (in seconds)																
	2	5	10	15	20	25	30	35	40	50	80	100	120	150	180	255

Legend:	
LED off	○
LED on	●
LED flashes slowly	
LED pulses	
LED flashes quickly	
Factory default setting	-
Not possible	-

DUAL DOOR INSTALLATION Fig. 28B

- In dual door installations, the transmitter (TX) and the receiver (RX) photo eye sensors (as marked on each of the photo eye components) should be mounted as indicate in Fig. 28B. TX and RX marks located on the back side of the transmitter and receiver.

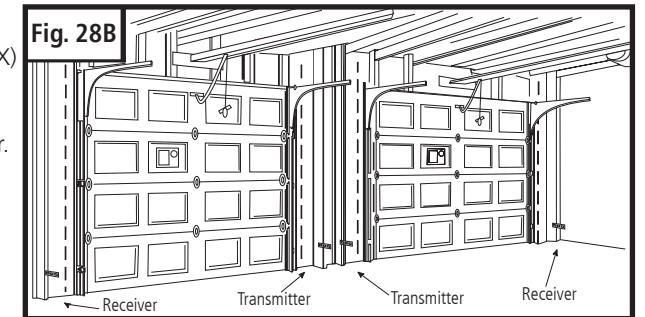

8-12. INSTALL WALL CONTROL PANEL

The control panel must be mounted inside the garage within sight of the garage door, clear of all moving garage door parts or any associated parts - and at least 5 feet above the floor to prevent the use of these controls by children. The device should only be used when the door is in clear sight of the user and the door area is free of people or any obstructions.

- Attach 2-conductor wire to the screw terminal on back of control panel. See Fig. 29 (Back). White wire attaches to terminal #3 screw, white wire with color stripes attaches to terminal #4 screw.
- Position wall control panel onto wall in desired location.
- Mark hole location on wall.
- Drill 1/16" pilot holes into wall.
- Insert and tighten screws to secure control panel to wall.
- Make sure wiring is routed out from behind control through one of the cutouts to avoid pinching the wires.

If mounting to drywall instead of wood, drill 3/16" pilot holes and use anchors provided. If mounting to electrical box that is prewired for this purpose, mount directly to box with proper screws provided. See Fig. 29A.

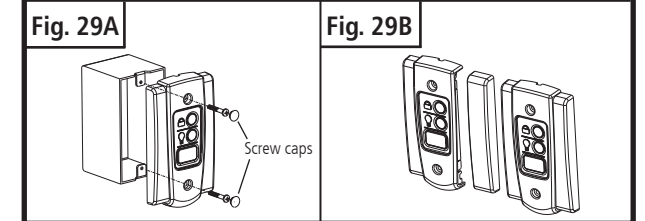
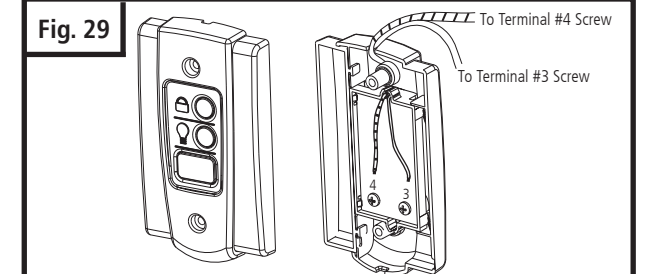

8-13. CONNECTING THE SAFETY SENSORS AND WALL CONTROL TO OPERATOR

- Run wires from the wall control panel along the wall and ceiling to the operator quick-connect terminals, locate on the rear. Use the staples to secure wiring to wall, joists and ceiling. Do not pinch wiring. Drive staples with only enough force to hold wiring in place. Refer to Fig. 6 on p.6 for an example of typical wiring routing, and Fig. 30 for terminal assignment.
- Insert white single wire from wall control into quick-connect terminal #3 and single color striped wire into quick-connect terminal #4. See Fig. 31.

NOTE: Individual wall control stations can be combined into one solid panel.

- Detach right side panel from one of the wall controls. (Fig. 29B)
- Attach wiring to each wall control.
- Combine single panels into one block.
- Follow the same steps as above to mount additional wall control panels and wire connections, **only connect one wall control per operator.**

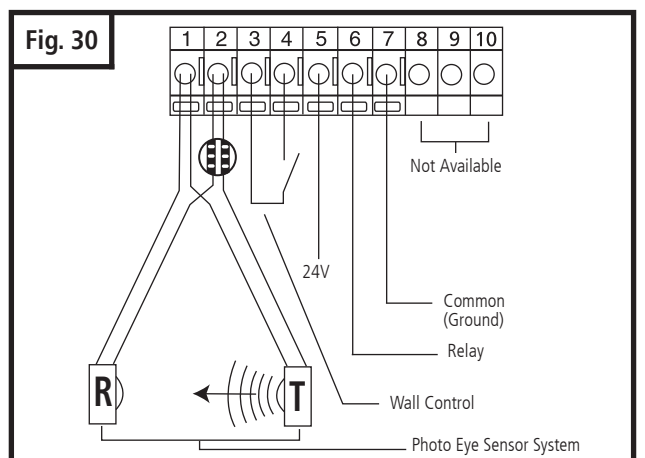

- For photo eye system wiring routing refrence section 8-11 on page 12, Fig. 25A.
- Insert the stripped end of the white wire combination firmly into quick-connect terminal #1 by pushing the wires directly in the terminal hole, see Fig. 32A. If the wires are difficult to insert, a screwdriver may be used to depress the terminal "tab" while inserting the wires. To remove wires, depress the tab again and pull wires out.
- Repeat procedure for the stripe wires (white/black stripe), insert them into quick-connect terminal #2.

NOTE: If wires are difficult to insert, a screwdriver may be used to depress the quick-connect terminal "tab" while inserting the wires. To remove wires, depress tab again and pull wires out.

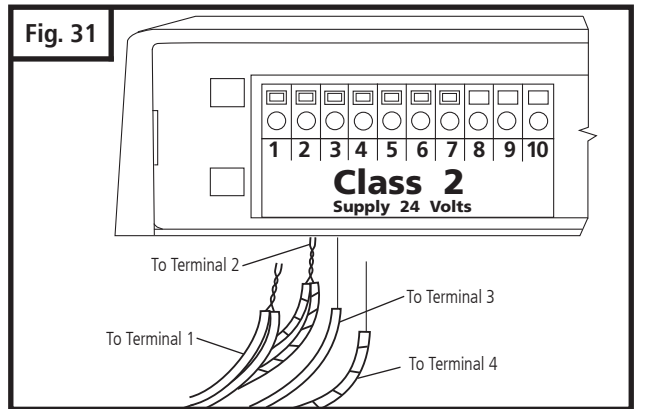

8-14. CONNECT TO POWER

To reduce the risk of electric shock, your operator is provided with an insulated power cord with a 3-prong grounding plug. The cord must be connected to a standard grounding outlet. If there is no outlet available at the location, you must have a qualified electrician install an approved grounded outlet in this area.

WARNING

To prevent electrocution or fire, installation and wiring must be done in accordance with local electrical and building codes. DO NOT use an extension cord. DO NOT use a 3 to 2 plug adapter. DO NOT modify or cut off the grounding pin on the plug.

- Plug the operator into a properly grounded outlet (Fig. 32).
- An indicator light (LED #8) on the operator control panel will turn on showing that the power is "On" and the operator is ready to set the adjustments.
- DO NOT operate or run the operator at this time.

PERMANENT WIRING CONNECTION:

(If required by your local electrical code)

If local codes require your operator to be connected via permanent wiring instead of a cord and plug, your operator must be converted, as shown in Fig. 33. Contact a qualified electrician to run the necessary wiring to your operator and to perform the electrical connections.

WARNING

To prevent electrocution, disconnect the operator from power and turn off power at circuit breaker for the circuit you will be using to connect to the operator.

- Remove operator housing by removing the four screws, two screws located at the front by the control panel area, and two screws located on the back of the unit, then pulling the housing away from the chassis.
- Cut the power cord close to strain relief cover, so that after cut, there is at least 6" of wiring remaining. Remove approximately 1-1/2" of black insulation left on the cable to expose the three conductor leads (white-neutral, black-hot, and green-ground).
- Remove two screws and unsnap the power cord strain relief cover by disengaging the tabs, and remove this part (save for reattachment later).
- Remove the cut power cord and discard. Replace the strain relief cover by snapping tabs back into place.
- Using a hammer and screwdriver or punch, knock out conduit hole, and bring in the permanent wiring and conduit.
- Secure conduit to chassis (method varies depending on type of conduit used).
- Attach the incoming power leads (hot, neutral, and ground) to the remaining internal wires using suitable wire nuts (not provided). Tight wire leads together with a nylon cable tie to avoid the leads from coming in contact with the relay circuit board, see Fig. 33A.
- Reinstall operator housing and secure housing with screws. Make sure that when reinstalling operator housing, no wires will be pinched between the housing and the chassis.
- Complete the remaining installation.
- Turn on power at breaker.

Fig. 32

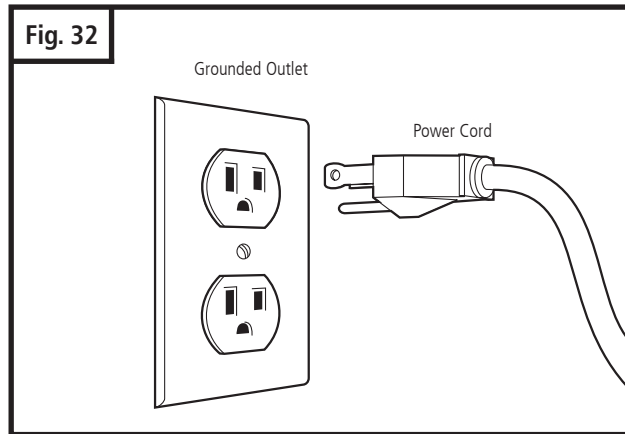

Fig. 33

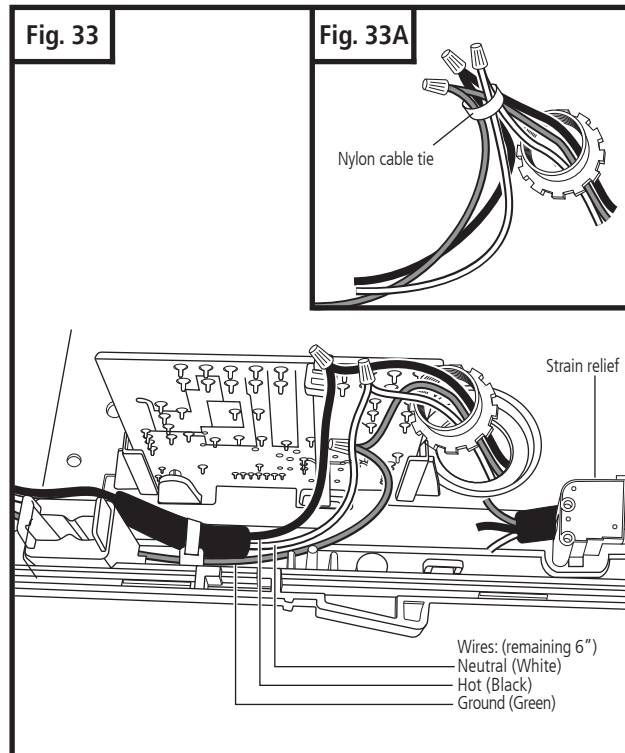
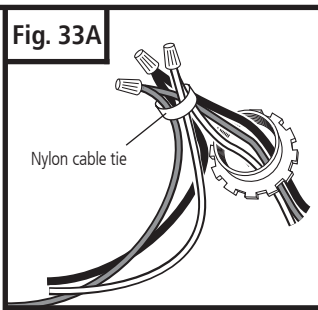

Fig. 33A



8-17. ADVANCED SETTINGS (cont'd)

Level 2: Functions overview

NOTE: Menus 5-7 are disabled

Press "+" or "-" button to scroll or navigate through menus.

CAUTION

The higher the sensitivity setting in menu 3 and 4, the higher the operator force capabilities or less sensitive operation.

Level 2 – Opener settings																
	1	2	3	4	5	6	7	8	9	10	11	12	13	14	15	16
Menu 1: "OPEN" position operator (system) operating force (scale from 1 to 16)	1	2	3	4	5	6	7	8	9	10	11	12	13	14	15	16
Menu 2: "CLOSED" position operator (system) operating force (scale from 1 to 16)	1	2	3	4	5	6	7	8	9	10	11	12	13	14	15	16
Menu 3: "OPEN" position operator sensitivity (sensitivity scale from 1 to 16)	OFF	2	3	4	5	6	7	8	9	10	11	12	13	14	15	16
Menu 4: "CLOSE" position operator sensitivity (sensitivity scale from 1 to 16)	OFF	2	3	4	5	6	7	8	9	10	11	12	13	14	15	16

Level 4 – Transmitter code programming	
Menu 1: Impulse	Not available
Menu 2: Intermediate position	LED 7 flashes slowly -> use transmitter button other than those designated for garage doors -> LED 7 flashes quickly

8-17. ADVANCED SETTINGS (cont'd)

CAUTION

After a system reset, all parameters are restored to the factory settings.

- All the required function in the initial set up and advanced settings must be re-programmed if it is required.
- The operator must be activated for two (2) complete uninterrupted cycles in order for all restored or operating parameters settings to be learned by the operator again.

General overview of the programmable functions

Level	Menu	Factory default setting
Level 1 – Basic function system reset	Menu 3: Intermediate position OPEN	–
	Menu 4: Not available	–
	Menu 5: Soft run position OPEN	–
	Menu 6: Soft run position CLOSE	–
	Menu 8: RESET	–
Level 2 – Opener settings	Menu 1: "OPEN" position – operating (System) force	Setting 8
	Menu 2: "CLOSE" position – operating (System) force	Setting 8
	Menu 3: "OPEN" position – operating sensitivity	Setting 15
	Menu 4: "CLOSE" position – operating sensitivity	Setting 15
Level 4 – Transmitter code programming	Menu 1: Not available	–
	Menu 2: Intermediate position	–
Level 5	Menu 4: Light timer	Setting 16

Level 1: Functions overview

NOTE: Menus 1, 2 and 7 are disabled. Press "+" or "-" button to scroll or navigate through menus.

Level 1	1	2	3	4	5	6	7	8	9	10	11	12	13	14	15	16
Menu 3: Intermediate position OPEN	Set using the (+ / OPEN) and (- / CLOSE) buttons															
Menu 4: Intermediate position CLOSE	not available															
Menu 5: Soft run position OPEN	Set using the (+ / OPEN) and (- / CLOSE) buttons															
Menu 6: Soft run position CLOSE	Set using the (+ / OPEN) and (- / CLOSE) buttons															
Menu 8: RESET	No	Yes	–	–	–	–	–	–	–	–	–	–	–	–	–	–

8-15. CONTROL PANEL

On the control panel (See Fig. 34) you will find circular LED display with 8 numbered icons which shows useful status information regarding the operator and its function and 3 buttons labeled "+", "-", and "P" which allows you to set all the adjustments of your operator.

8-16. INITIAL SYSTEM SET UP

WARNING

In order to guarantee a trouble-free programming:

- The door must be in the "CLOSED" position and engaged to the drive system (rail) before programming the operator or a system reset is performed.

IMPORTANT: Align the photo eye sensors before starting the initial system set up as outlined in section 8-19, page 21.

For proper initial operation of the operator, three basic functions must be set using express programming:

- Open Door Position
- Close Door Position
- Transmitter Coding

Press and hold the "P" button for approximately 2 seconds. When LED's 8, 1 and 2 illuminate, release the button. You are now ready to set or change the desired adjustment. If no buttons are pressed within 120 seconds while in programming mode, the control unit reverts back to operating mode.

TO MAKE OR CHANGE ANY ADJUSTMENT:

HANDY NOTE: If no changes are needed at any particular stage, you can keep the current information and "skip" over a specific adjustment by pressing the "P" button once. This is useful to know if you want to change only one setting, without changing any of the other adjustments. Simply enter the adjustment mode by pressing and holding the "P" button for approximately 2 seconds, then press and release "P" repeatedly until your particular adjustment is reached. This bypasses the unneeded adjustments, and takes you right to the adjustment you want. When your adjustment or setting is complete, simply press "P" as many times as needed to bypass the remaining steps and exit out of the program, returning the operator to normal mode.

Your new operator has automatic force learning and maximum force setting. It may be required to change force settings. If the force needs to be increased or decreased, it should be changed by one (1) increment at a time. The force should be set as low as possible, just enough to allow your unobstructed door to travel freely without reversing or stopping.

NOTE: You may exit the System Set Up at any time by pressing the button "P" for more than 5 sec. The set up programming can be terminated at any time and from any stage. To do so, press the "P" button for longer than 5 seconds. When programming is terminated, all LED's light up once and then turn off, one after the other.

Fig. 34

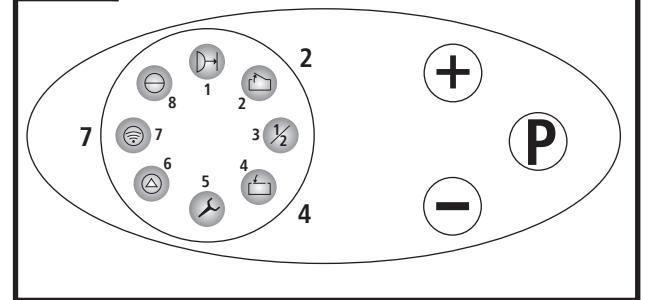
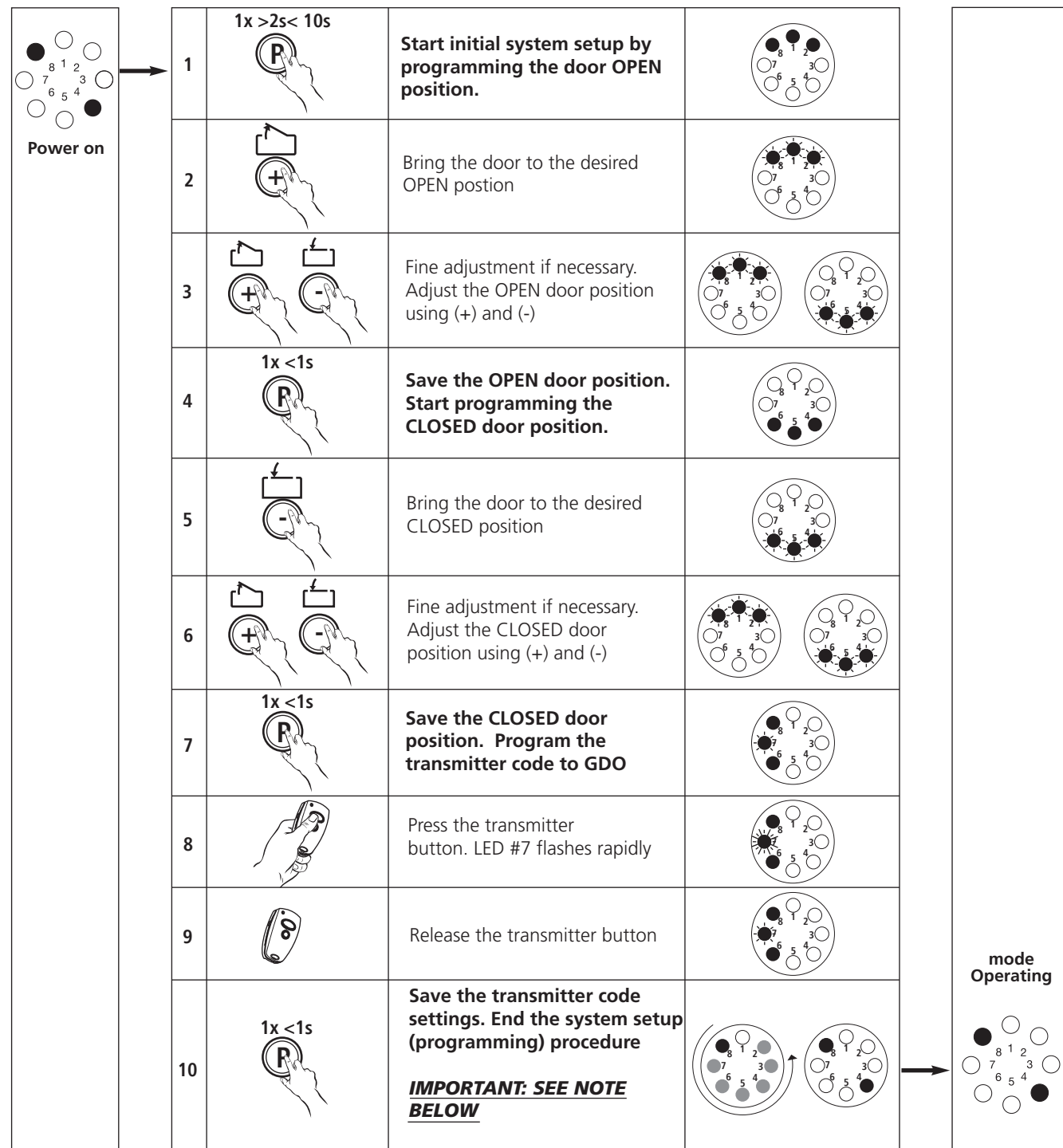

Fig. 35

Icons Description and LED's Assignment		
	LED #1	Photo Eye Sensors Connectivity/Alignment Indicator
	LED #2	"OPEN Door Position"
	LED #3	"Intermediate, OPEN Door Position"
	LED #4	"CLOSED Door Position"
	LED #5	"Reference Point"
	LED #6	-----
	LED #7	"Impulse (Remote Control)"
	LED #8	"Power"

8-16. INITIAL SYSTEM SET UP (cont'd)



mode
Operating

IMPORTANT:

Upon completion of the initial set up, the operator must be cycled for two complete cycles (complete cycle comprises of one uninterrupted up activation of the system and one uninterrupted down activation of the system).

Legend:

LED off	
LED on	
LED flashes slowly	
LED pulses	
LED flashes quickly	
Factory default setting	
Not possible	-

8-17. ADVANCED SETTINGS

Advanced settings programming flow chart (Diagram illustrates: Level 2, Menu 2)

CAUTION
Additional operator functions can be set using the advanced operator functions. Parameters factory default settings can be restored. This programming may only be carried out by a professional installer.

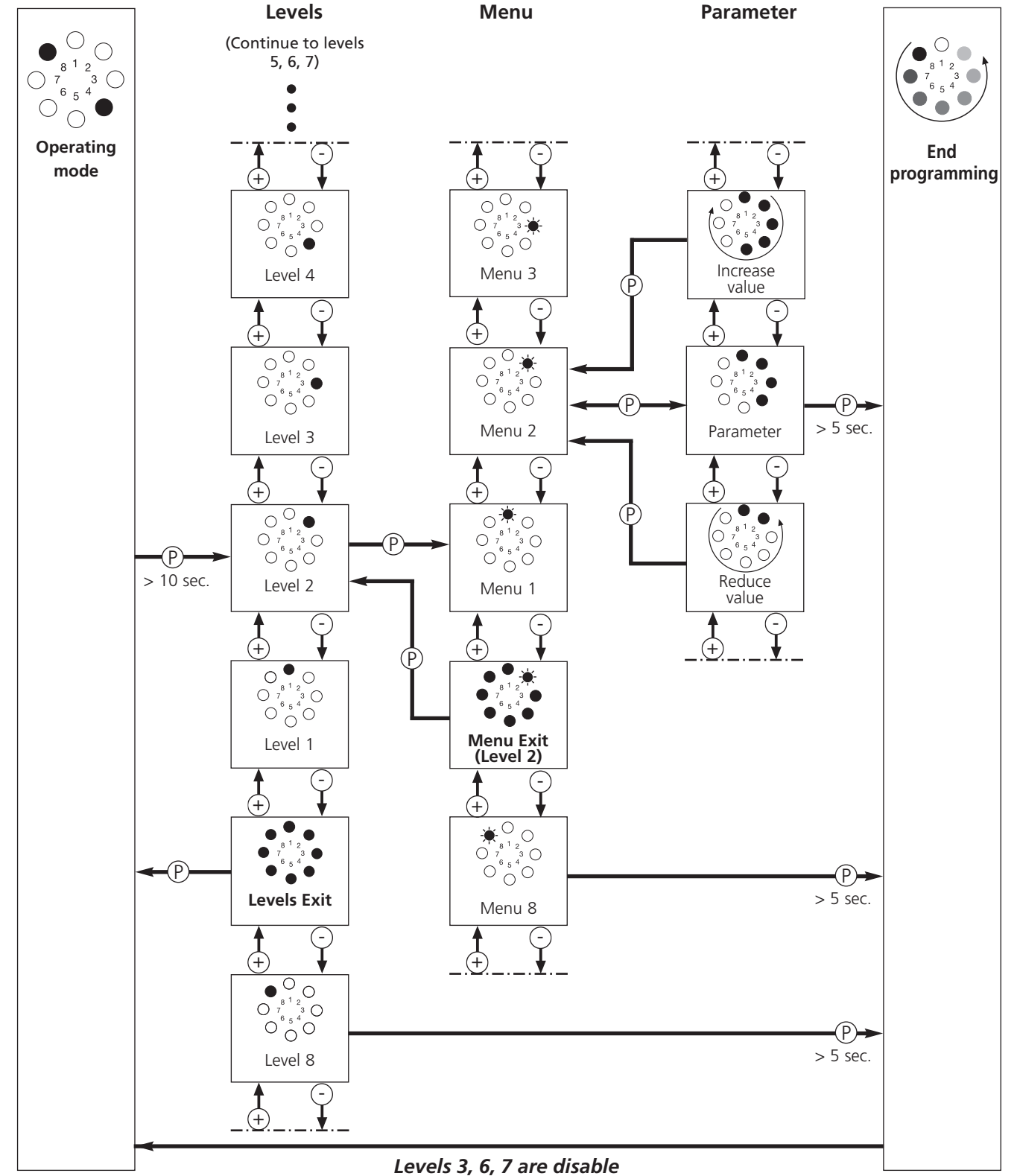

Levels 3, 6, 7 are disable